

# iCt Area Scan Cameras User Manual

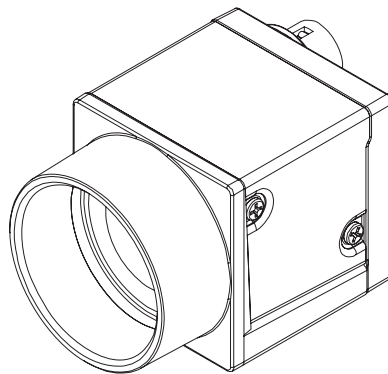

V26.03

---

## Preface

### Purpose

---

This Manual is a basic description of iCt Area Scan Cameras, which mainly includes the product description, quick installation guide and Simple introduction of SDK(iCentral).

---

Copyright ©2025  
Hangzhou Vision Datum Technology Co., Ltd.  
Tel.: +86 571-86888309  
Add.:No. 8 Xiyuan 9th Road, West Lake District Hangzhou Zhejiang 310030 China.

All rights reserved. The information contained herein is proprietary and is provided solely for the purpose of allowing customers to operate and/or service Vision Datum manufactured equipment and is not to be released, reproduced, or used for any other purpose without written permission of Vision Datum.

### Disclaimer

The information and specifications described in this manual are subject to change without notice.

### Latest Manual Version

For the latest version of this manual, see the Download Center on our web site at: <http://www.visiondatum.com/en/service/005001.html>

### Technical Support

For technical support, e-mail: [support@visiondatum.com](mailto:support@visiondatum.com).

### Warranty

To ensure that your warranty remains in force, adhere to the following guidelines:

**Do not remove the camera's serial number label**

If the label is removed and the serial number can't be read from the camera's registers, the warranty is void.

**Do not open the camera housing**

Do not open the housing. Touching internal components may damage them.

**Prevent ingress or insertion of foreign substances into the camera housing**

Prevent liquid, flammable, or metallic substances from entering the camera housing. If operated with any foreign substances inside, the camera may fail or cause a fire.

**Avoid electromagnetic fields**

Do not operate the camera in the vicinity of strong electromagnetic fields. Avoid electrostatic charging.

**Clean with care**

Avoid cleaning the sensor if possible.

**Handle this camera with care**

Do not abuse the camera. Avoid striking, shaking, etc. The camera could be damaged by improper handling.

**Read the manual**

Read the manual carefully before using the camera.

## CHAPTER 1 Overview

### Product Introduction

The iCt series industrial cameras compatible with GigE and USB3.0 Vision protocol, support GenICam、USB3 Vision® and GigE Vision®, Smoothly connect with third-party software, like HALCON and Vision Pro, not need for secondary development. iCt series cameras with excellent cost performance and very suitable for various inspections measurement and high-speed imaging applications. This series cameras won customers high praise because its outstanding performance in cellphone and tablet PC screen inspection, LED automatic packaging, defect inspection, and electronic components manufacturing, wafer positioning and other applications.

With this variety of sensors and interfaces, combined with the extensive features offered, iCt series cameras are fit for a wide range of vision applications.

### Product Features

- Ethernet interface provides 1Gbps bandwidth, with maximum 100m transmission;
- USB3.0 interface supports theoretical 5Gbps bandwidth. USB interface also provides power supply;
- 256MB on-board frame buffer for image data retransmission under burst mode;
- Supports software trigger, external trigger, mixed mode, free run mode and etc.;
- Supports sharpness, noise reduction, gamma correction, LUT, black level correction, brightness, contrast and other ISP functions;
- Supports interpolation algorithm, white balance algorithm, color conversion matrix, hue, saturation and etc. for color camera;
- Supports various output formats for image data and supports ROI, binning, mirror and etc.;
- Conforms to GigE Vision V2.0 / USB3 Vision protocol and GenICam standard;
- Supports POE power supply and DC 9V~24V wide-range power supply for GigE Cameras.

## Mechanical Dimensions

The dimensions is in millimeters:

- GigE Cameras with 29 \* 29 \* 42mm housing are as shown in Figure 1-1.
- GigE Cameras with four-sided mounting 29 \* 29 \* 42mm housing are as shown in Figure 1-2.
- USB3.0 Cameras with four-sided mounting 29 \* 29 \* 30mm housing are as shown in Figure 1-3.
- GigE Cameras with 29 \* 44 \* 58mm flat housing are as shown in Figure 1-4.
- USB3.0 Cameras with 29 \* 44 \* 58mm flat housing are as shown in Figure 1-5.
- Dual USB3.0 Cameras with 29 \* 44 \* 58mm flat housing are as shown in Figure 1-6.

There are two M2 locking screw holes on both sides of the Ethernet port to secure the network cable and prevent loosening caused by on-site vibration. Mounting holes are provided on the bottom of the camera housing, as shown in the figure:

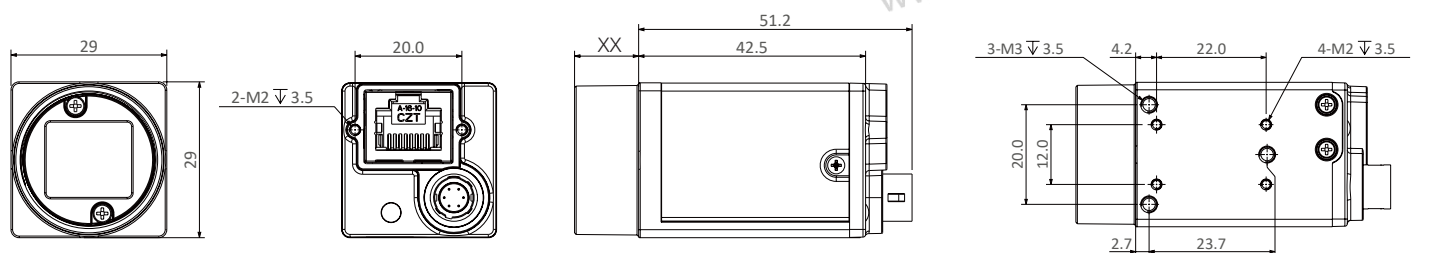

Fig. 1-1: Mechanical Dimensions (in mm) for GigE Cameras with 29\*29\*42mm housing.

Model	XX Length	Model	XX Length
iCt20MG/CG4A-SE iCt20MG/CG16A-SE iCt20MG/CG19A-SE	11.45mm	iCt10MG/CG24A-SE	12mm
iCt20MG/CG13A-SE	11.7mm	iCt90MG/CG60A-SE iCt90MG/CG120A-SE	12.05mm
iCt00MG/CG13A-SE	11.95mm	iCt90MG/CG4A-SE iCt90MG/CG16A-SE iCt9SMG/CG16A-SE iCt90MG/CG50A-SE	12.1mm
iCt70MG/CG50A-SE	11.85mm		

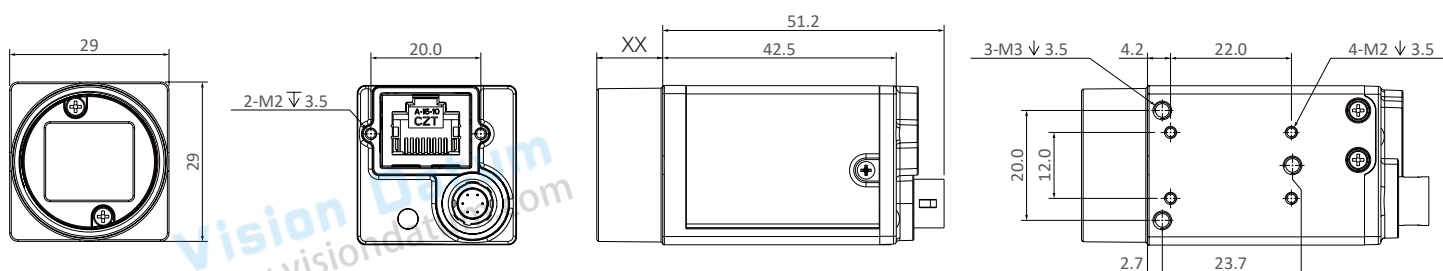

Fig. 1-2: Mechanical Dimensions (in mm) for GigE Cameras with 29 \* 29 \* 42mm flat housing.

Model	XX Length	Model	XX Length
iCt10MG/CG24A-Pro	11.5mm	iCt90MG/CG4A-Pro iCt9SMG/CG4A-Pro iCt90MG/CG16A-Pro iCt9SMG/CG16A-Pro iCt90MG/CG50A-Pro iCt90MG/CG90A-Pro iCt9SMG/CG120A-Pro iCt90MG/CG200A-Pro iCt90MG/CG240A-Pro	11.6mm
iCt90MG/CG20A-Pro iCt90MG/CG60A-Pro iCt90MG/CG120A-Pro iCt9SMG/CG200A-Pro	11.55mm		
iCt70MG/CG200A-Pro	11.7mm		
iCt10MG/CG120A-Pro	12mm		

## Mechanical Dimensions

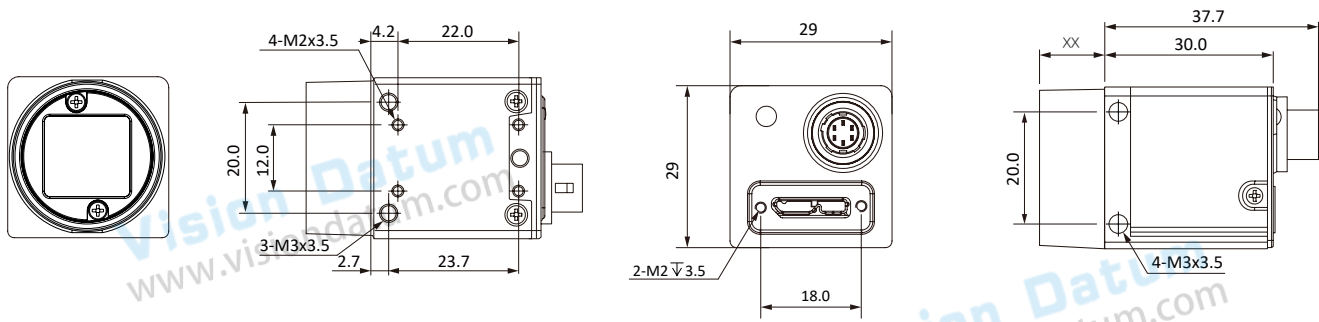

Fig. 1-3: Mechanical Dimensions (in mm) for USB3.0 Cameras with four-sided mounting 29 \* 29 \* 30mm housing.

Model	XX Length	Model	XX Length
iCt10MU/CU24A-Pro	11.5mm	iCt70MU/CU200A-Pro	11.7mm
iCt90MU/CU20A-Pro iCt90MU/CU60A-Pro iCt90MU/CU120A-Pro iCt9SMU/CU200A-Pro	11.55mm	iCt90MU/CU4A-Pro iCt90MU/CU16A-Pro iCt9SMU/CU50A-Pro iCt9SMU/CU90A-Pro iCt9SMU/CU120A-Pro	11.6mm

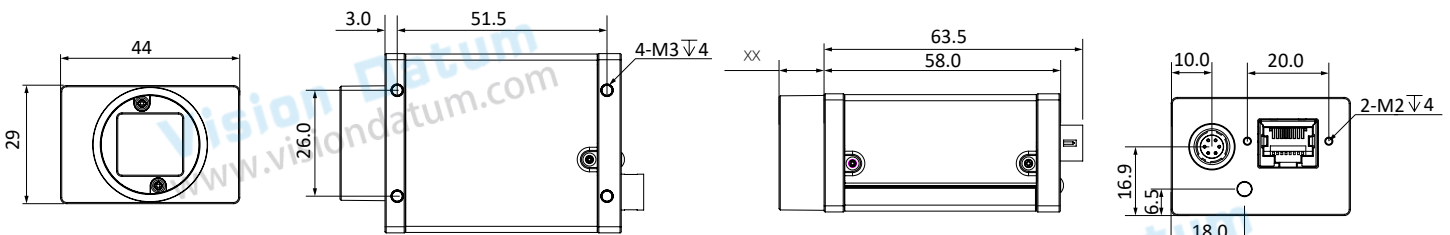

Fig. 1-4: Mechanical Dimensions (in mm) for GigE Cameras with four-sided mounting 29 \* 44 \* 58mm flat housing.

Model	XX Length	Model	XX Length
iCt10MG/CG250A-Pro-K	11.05mm	iCt00MG/CG100A-Pro-K	9.9mm

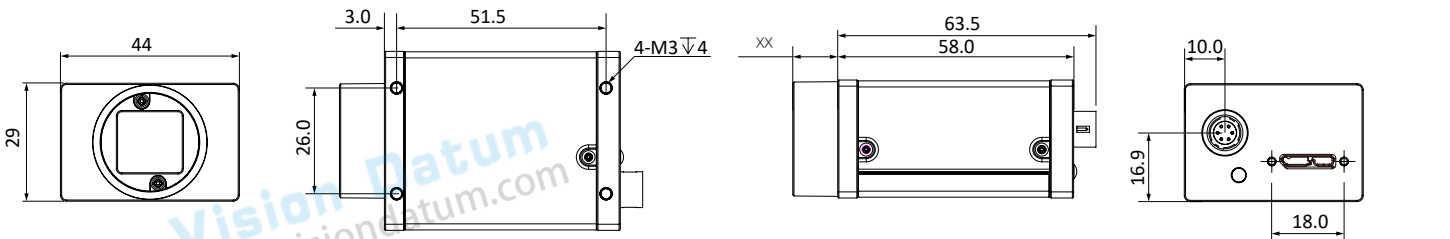

Fig. 1-5: Mechanical Dimensions (in mm) for USB3.0 Cameras with 29 \* 44 \* 58mm flat housing.

Model	XX Length	Model	XX Length
iCt10MU/CU250A-Pro-K	11.05mm	iCt00MU/CU100A-Pro-K	9.9mm

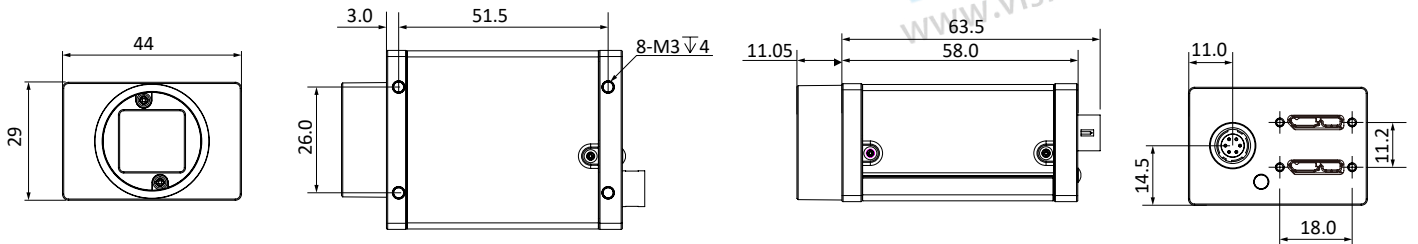

Fig. 1-6: Mechanical Dimensions (in mm) for Dual USB3.0 Cameras with 29 \* 44 \* 58mm flat housing.

Model	XX Length
iCt10MW250A-Pro-K	11.05mm

## Status LED Description

Mode	Status LED		Description
Normal	Red	Fast Flashing Red	The device is starting.
	Blue	Low-light Blue	IP has been assigned, Software API is not connected with the device.
		High-light Blue	API is connected with the device, free mode, No image transmission
		Fast Flashing Blue	API is connected with the device, free mode, with image transmission
		Slow Flashing Blue	Using trigger mode.
Red ↔ Blue	Flashing Alternately Red and Blue	Firmware is upgrading.	
Abnormal	Red	Steady Red	Device malfunction
		Slow Flashing Red	The Network is disconnected.

Vision Datum  
www.visiondatum.com

Vision Datum  
www.visiondatum.com

Vision Datum  
www.visiondatum.com

Vision Datum  
www.visiondatum.com

## Avoiding EMI and ESD Problems

The cameras are frequently installed in industrial environments. These environments often include devices that generate electromagnetic interference (EMI) and they are prone to electrostatic discharge (ESD). Excessive EMI and ESD can cause problems with your camera such as false triggering or can cause the camera to suddenly stop capturing images. EMI and ESD can also have a negative impact on the quality of the image data transmitted by the camera.

To avoid problems with EMI and ESD, you should follow these general guidelines:

- Always use high quality shielded cables. The use of high quality cables is one of the best defenses against EMI and ESD.
- Try to use camera cables that are only as long as necessary and try to run the camera cables and power cables parallel to each other. Avoid coiling camera cables. If the cables are too long, use a meandering path rather than coiling the cables.
- Avoid placing camera cables parallel to wires carrying high-current, switching voltages such as wires supplying stepper motors or electrical devices that employ switching technology. Placing camera cables near to these types of devices can cause problems with the camera.
- Attempt to connect all grounds to a single point, e.g., use a single power outlet for the entire system and connect all grounds to the single outlet. This will help to avoid large ground loops. (Large ground loops can be a primary cause of EMI problems.)
- Use a line filter on the main power supply.
- Install the camera and camera cables as far as possible from devices generating sparks. If necessary, use additional shielding.
- Decrease the risk of electrostatic discharge by taking the following measures:
  - Use conductive materials at the point of installation (e.g., floor, workplace).
  - Control the humidity in your environment. Low humidity can cause ESD problems.

## Precautions

### NOTICE

#### Cleaning of the sensor and the housing

##### Sensor

Avoid cleaning the surface of the camera's sensor if possible. If you must clean it:

- Before starting, disconnect the camera from camera power and I/O power.
- Use a soft, lint-free cloth dampened with a small amount of high-quality window cleaner.
- Because electrostatic discharge can damage the sensor, you must use a cloth that won't generate static during cleaning (cotton is a good choice).
- Make sure the window cleaner has evaporated after cleaning, before reconnecting the camera to power.

##### Housing

To clean the surface of the camera housing:

- Do not use solvents or thinners; they can damage the surface.
- Use a soft, dry cloth that won't generate static during cleaning (cotton is a good choice).
- To remove tough stains, use a soft cloth dampened with a small amount of neutral detergent; then wipe dry.

### NOTICE

#### An incorrect plug can damage the I/O connector.

The plug on the cable that you attach to the camera's I/O connector must have 6 female pins. Using a plug designed for a smaller or a larger number of pins can damage the connector.

### NOTICE

#### Keep the sensor free from dust.

The camera lens mount is fitted with a plastic cap. To prevent dust accumulation on the camera's IR cut filter (for color cameras) or sensor (for mono and NIR cameras), always keep the lens cap attached when no lens is mounted on the camera.

To avoid dust buildup on the camera's IR cut filter (for color cameras) or sensor (for mono and NIR cameras), strictly observe the following guidelines:

- Always keep the plastic cap properly in place when no lens is installed on the camera.
- Ensure the camera is facing downward each time you remove or replace the plastic cap, lens, or lens interface.
- Never use compressed air on the camera, as this can easily contaminate optical components, especially the sensor.

## CHAPTER 2 I/O Wiring and Electrical Characteristics

### I/O Connection Definition and Assignments

The camera rear appearance contains standard RJ45/USB3.0 interface, 6pin power and I/O input connector and camera working status indicator light. The camera uses a 6-pin connector for external I/O and power supply, with the connector model being \*\*Hirose HR10A-7R-6PB\*\* or equivalent. The pin assignment diagram of the camera's 6-pin I/O interface is shown below.

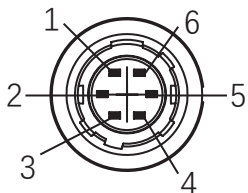

Table 2-1:  
Numbering and assignments  
for 6pin Power and I/O Input  
Connector

Color	Pin	Signal	Description
Red	1	-	+9~24VDC Camera Power
Green	2	Line1	Opto-coupler Isolated Input
White	3	Line2	GPIO(Non-isolated software configurable input and output I/O)
Blue	4	Line0	Opto-coupler Isolated Output
Brown	5	GND	Opto-coupler Isolation Signal Ground (ISO_GND)
Black	6	-	DC Camera Power Ground and GPIO Signal Ground (GND)

1.Pin1 is used as the camera's auxiliary power supply input. When the output power of the USB port of the PC is insufficient or the USB cable is long, please use this pin to provide power to the camera to ensure reliable operation of the camera.



For PoE-powered cameras, when both PoE and external adapter are powering the camera at the same time, the camera will preferentially use the adapter power.

### I/O Interface

Recommendations for the I/O cable.:

- The I/O cable must be shielded.
- You should use a twisted pair wire.
- Maximum recommended cable length: 10 m
- Pin assignment (see Table 2-1)
- Close proximity to strong magnetic fields should be avoided.

Depending on the particular application, using different cables may lead to voltage drops, signal distortion, and EMI/ESD problems which in turn may cause the camera to malfunction.



Note that direct-coupled GPIO lines have the advantage of working with very short delays compared to opto-isolated I/O lines.

Note also that the direct-coupled GPIOs are distinctly more susceptible to EMI than the opto-isolated I/Os. Under harsh EMI conditions, GPIOs can turn out not to be usable at all.

Accordingly, use of the GPIOs in an environment with elevated risk of EMI calls for taking additional measures like, e.g. using shorter cables.



The recommend connector model of cable is HR10A-7P-6S or other connectors with same quality. Using the improper connector may cause damages to the interface of camera.

## CHAPTER 3 Installation and Setup

### Software Installation

#### ■ iCentral Installation

If you use a firewall on your computer, disable the firewall for the network adapter to which your camera is connected.

##### Close the Firewall

In order to ensure the camera software keep running and image transmission stability, please close the firewall before using the software.

##### System Requirements

Mars Camera Software Suite for Windows requirements that one of the following operating systems is installed on your computer:

- Windows 7 (32 bit or 64 bit)
- Windows 10 (32 bit or 64 bit)

##### Installation Steps

1.You can download the iCentral software from:

<http://www.visiondatum.com/service/005001.html>

2.Double click iCentral installation package to install the client.

3.Follow the instructions on the screen. The installer will guide you through the installation process.

## Hardware Installation

### ■ Installing a GigE Camera



If you use a firewall on your computer, disable the firewall for the network adapter to which your camera is connected.

The installation procedures assume that you will be making a peer-to-peer connection between your camera and a computer. Make sure that the following items are available before starting the installation:

- A GigE camera;
- As applicable, a power supply or a GigE power injector;
- As applicable, a C-mount lens for the camera;
- A computer with a GigE network adapter installed; (The computer must be equipped with an appropriate operating system.)
- A standard Ethernet patch cable(CAT 5E or better).

You should perform the software installation procedure first and the hardware installation procedure second.

#### Steps:

1. Mount a C-mount lens with adapter onto your camera. For C-mount lens, make sure that the lens is screwed into the camera's lens adapter as far as it will go;
2. Connect the camera to the computer and power.

#### If you are using PoE:

- a. Connect one end of a network cable to the network connector of the power injector labeled "Data In" and connect the other end of the cable to the network connector of the GigE network adapter in your computer;
- b. Connect one end of the AC cable for the power injector to the injector's body and the other end to an AC outlet;
- c. Connect one end of a network cable to the network connector of the power injector labeled "PoE Out" and connect the other end of the cable to the network connector of the camera.

#### If you are using 6-Pin Hirose cable:

- a. Plug one end of an Ethernet cable into the network adapter in your computer and the other end of the cable into the GigE connector of the camera;
- b. Plug the 6-pin connector of the cable from your power supply into the 6-pin connector of the camera.
- c. Switch on the power supply

### Network Settings

Before using the camera, you need to configure IP is in the same network segment with the computer. You can modify it in "Local Connection" to ensure network communication is normal.

Local Network Configuration :

- Click "Control Panel"> "Network and Internet"> "Network and Sharing Center"> "Change Adapter Configuration." Then select corresponding network card to configure it automatically obtain IP address or manually assign it as same network segment address with the camera. Shown as below:
- Open "Advanced" in the properties, set "Jumbo Frame" as its maximum value:9014bytes, both of transmit buffer and receive buffer set as 2048bytes, the Interrupt Throttle Rate set as extremum value. These maximum values mentioned above depend on the specific network card. Shown as below:

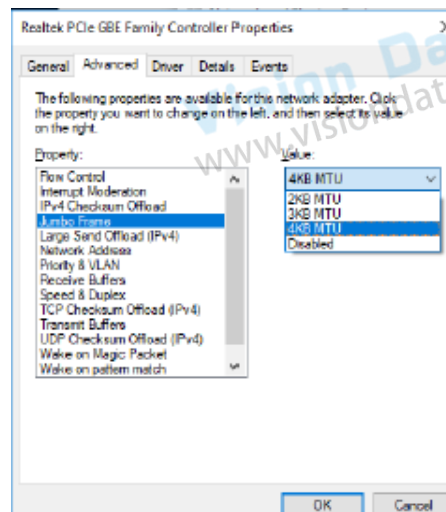

## Hardware Installation

### ■ Installing a USB 3.0 Camera

The installation procedures assume that you will be making a peer-to-peer connection between your camera and a computer. Make sure that the following items are available before starting the installation:

- A USB 3.0 Area Scan camera;
- As applicable, a C-mount lens for the camera;
- A computer with a USB port;
- A USB cable. Contact our sales representative for ordering a suitable cable assembly.

You should perform the software installation procedure first and the hardware installation procedure second.

#### Steps:

1. Remove the protective cap from the lens mount;
2. Mount a lens on the camera;
3. Mount the camera in your test setup;
4. If you want to use any of the camera's I/O lines, carry out the following steps:
  - a. Connect one end of the I/O cable to the I/O connector of the camera;
  - b. Connect the other end of the I/O cable to the device intended for sending and receiving I/O signals.
5. Connect the USB cable:
  - a. Connect one end of the USB cable to the USB Micro-B receptacle on the camera.
  - b. Connect the other end of the USB cable to a USB port of your computer.

We strongly recommends connecting the camera to a USB 3.0 port. When connected to a USB 2.0 port, functionality and data transmission rate of the camera will be limited.

The camera will power up. Windows will find the suitable camera driver in the Mars Camera Software Suite.

You can also use iCentral to check whether your camera was detected; acquire images, display images, and adjust parameter settings to improve image quality.

## Software Operation

### ■ iCentral Operation

1、Double-click the iCentral shortcut on the desktop to open up the client software.

#### ■ Main interface

For specific main window of the client software, please refer to the actual one you got.

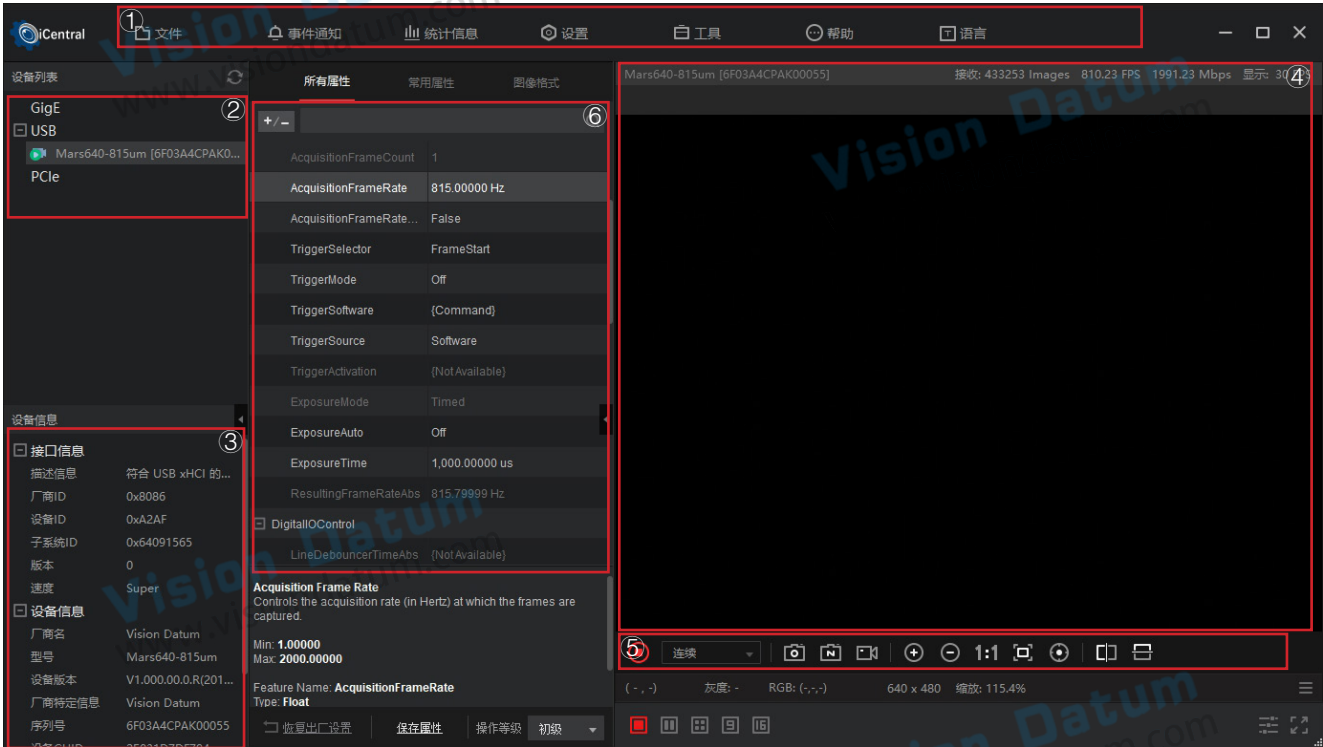

No.	Parameter	Description
①	Menu Bar	See the table below for details.
②	Device List	Including four types: GigE, USB and CameraLink, PCIe. Click the refresh icon to manually refresh the online device information.
		<ul style="list-style-type: none"> <li> Indicates that the device can be connected.</li> <li> Indicates that the device is already connected. The iCentral can connect with or operate one camera once.</li> </ul>
③	Device Information	Includes the interface info that the device is connected and the camera info.
④	Display	Includes stream, frame rate, bandwidth, display frame rate, errors, image resolution and so on.
⑤	Tool bar	Play/Stop. There are three mode of acquiring images: Continuous, Single frame, multiple frames.
		Save single/multi-frame pictures.
		Zoom in/Zoom out the displayed image.
		1:1/Display the image according to the display panel size/Image centered (The image is centered back to the center when it is dragged).
⑥	Property panel	Expand or merge all merged or expanded attributes.

## Software Operation

2、Click ">" in the camera's feature panel to unfold the specific camera parameters, and set them according to actual demands. Please see the table below for the introduction of each attribute classification.

Attribute	Description
<i>DeviceControl</i>	You can view the device information, edit its name, reset the device, etc.
<i>ImageFormatControl</i>	You can view and set the device's resolution, image reverse function, pixel format, region of interest, test pattern, etc.
<i>AcquisitionControl</i>	You can view and set the device's acquisition mode, frame rate, trigger mode, exposure time, etc.
<i>DigitalIOControl</i>	You can set the different input and output signals.
<i>EventControl</i>	You can view and set the type of event message.
<i>AnalogControl</i>	You can view and set the device's gain, black level, Gamma correction, sharpness, etc.
<i>LUTControl</i>	You can view the Look-Up Table (LUT), and set its index and value.
<i>TransportLayerControl</i>	You can view and set the parameters of the device's transport layer.
<i>UserSetControl</i>	You can view and set the camera's save and load User Set, and you can also set the User Set that is started by default.
<i>ColorTransformation Control</i>	You can view and set the device's color transformation related parameters like hue and saturation.
<i>CounterAndTimerControl</i>	You can view and set the counter related parameters.
<i>ISPControl</i>	You can view and set the sharpness, brightness, saturation, contrast, etc.

 The camera's attribute tree and parameters may differ by camera models.

### ■ Menu Bar

The menu bar for iCentral client provides following functions: File, View, Settings, Tool and Help, as shown in the figure below.

Menu		Description
<i>File</i>	Open	Opens a new *.mvcfg format file. Select "File> Open File" and select a file in the pop-in, click "Open."
	Open Recent	Select "File> Open Recent File", the software displays the 10 files that the user has recently used in iCentral. Click the name of a file to open it directly.
	Save	Save the changes to the current file.
	Save as	Save the current file to another location.
<i>Event</i>	Event Monitor	Including GenIcam paramters updates, messaging channel events and PvStream buffers.
<i>Statistics</i>	<i>Statistics</i>	Count the acquisition(FPS), bandwidth, received images, lost blocks, and error images.
<i>Settings</i>	General Settings	Visibility: Beginner, Expert, Guru. Each state can see different parameters in the property panels.、 Refresh device list、 Restore default parameters
	Image Save	Save the video stream data as a picture file.
	Record Video	Save the video stream data as a video file.
	Buffer Options	Set the number of buffers for video stream data.
	Communication Control	Set the number of packets lost during the timeout of the video stream.
<i>Tools</i>	CamTools	Firmware upgrade, SPC correction, FPN/FFC correction.
	Driver Tool	Check the installation status of GigE Vision, USB3 Vision, DirectShow, and provide quick installation
	NIC Tool	Network port camera network settings.
<i>Help</i>	About	Shows the current version No. of iCentral.
<i>Lang</i>	Chinese/English	switch Chinese/English

## CHAPTER 4 Image Acquisition

### Shutter

The shutters of camera include global shutter and rolling shutter. Which kind of shutter the camera should use is mainly related to the characteristics of the sensor.

#### ■ Global Shutter

The principle of global shutter is exposing the whole scene at the same time. All pixels of sensor start collecting the light simultaneously when camera start exposure. At the beginning of the exposure, the sensor starts collecting light; at the end of the exposure, the light collecting is stopped, and the sensor reads out the data of the image line by line, as shown in the figure below.

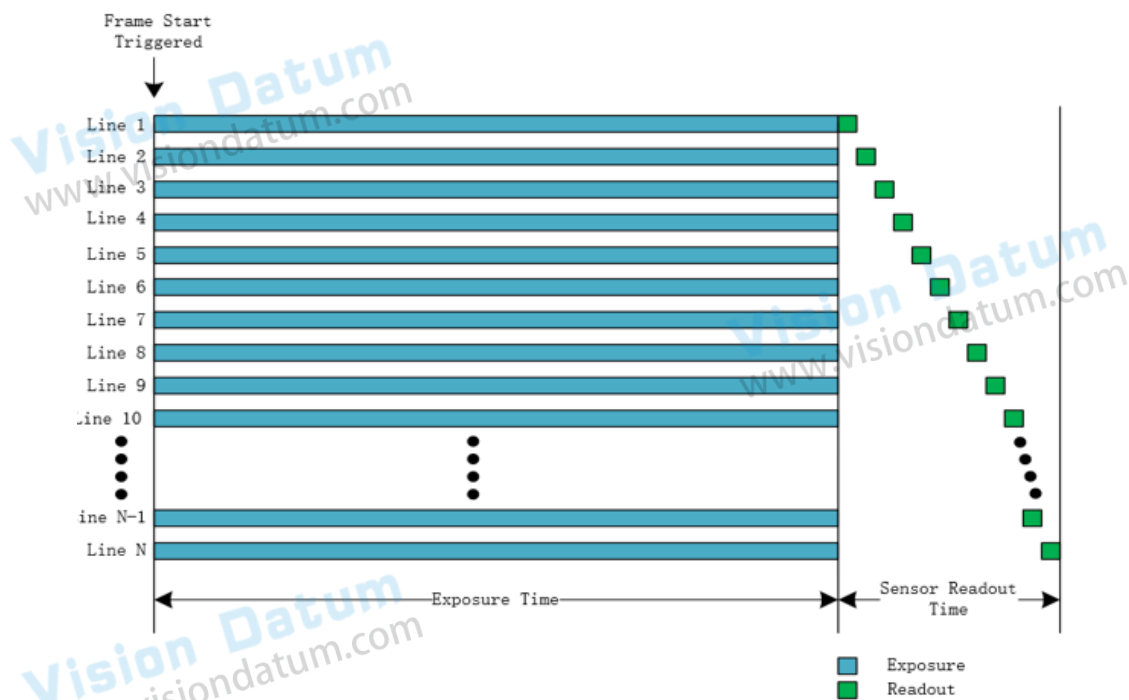

We recommend you use the global shutter mode when objects are moving quickly. This mode has no time difference in exposure and light collecting. However, the quantity limit of analog-to-digital converter (ADC) in single sensor restricts the rate of transmission and digitization for individual pixels, resulting in lower image acquisition speed and frame rates.

## Shutter

### Rolling Shutter

The principle of rolling shutter is the line-by-line exposure of sensor. The sensor equips an ADC for each column of pixels, which can significantly shorten the conversion time to improve the frame rate of camera. At the beginning of exposure, the sensor scans objects line by line and performs exposure line by line; after completing the exposure for each line, the data will be readout immediately, and after the data of current line is read, the data of next line will be read. The start time difference of exposure between two adjacent lines is the line data readout time, and the exposure time of each line equals to the readout time of each line. This cycle continues until all pixels are exposed and readout, as shown in the figure below.

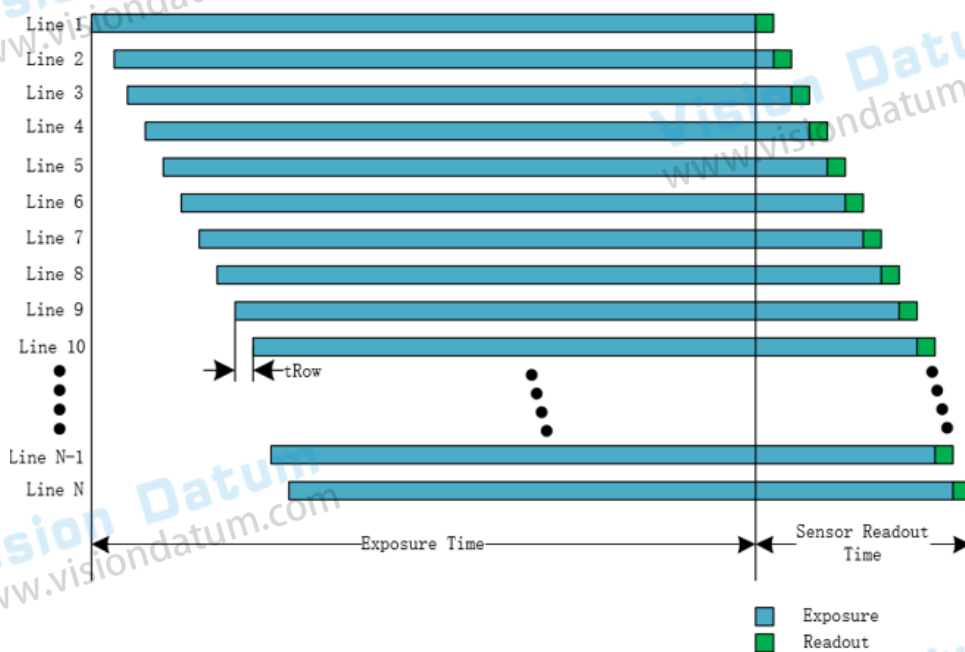

When camera scans the object when it is in the rolling shutter mode, some images will be distorted, smeared, swayed, etc, which is called Jelly Effect. Some cameras in the rolling shutter mode supports the global reset release shutter mode, and it is an optimized variant based on the rolling shutter mode. The global reset release shutter mode simulates the global exposure on the basis of rolling shutter exposure. It can expose all lines at the same time by using flash light, and end exposure from top line to bottom line which can effectively avoid the smearing, as shown in the figure below.

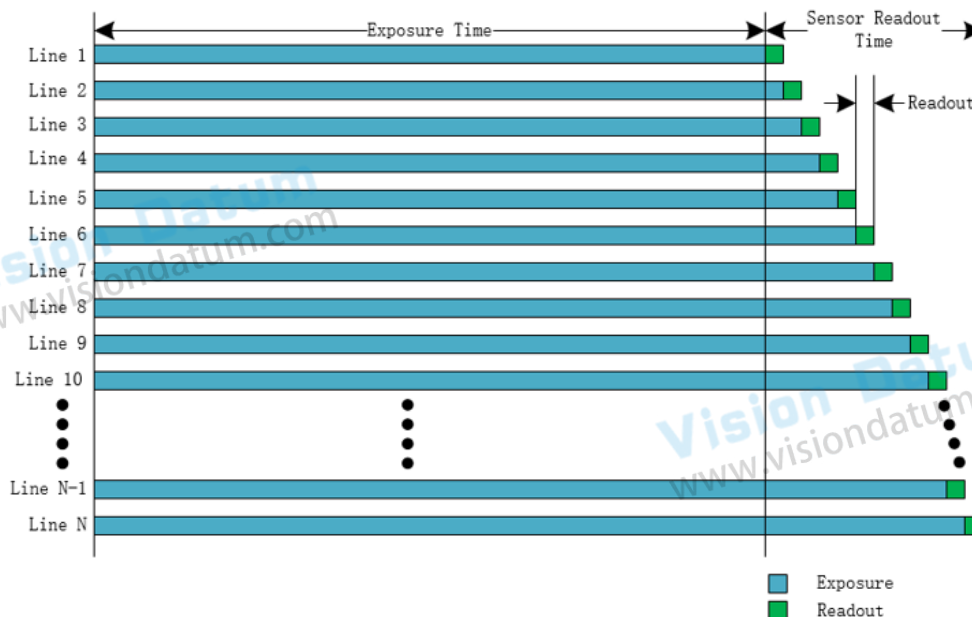

For the global reset release shutter, the exposure start time of each line is the same, but the end time is different; therefore, the exposure time of each line will be slightly different.



- The supported shutter modes may vary depending on the device model and sensor. The detailed information, please refer to the corresponding technical specifications.
- The rolling shutter and global reset release shutter are both supported in some cameras, which is related to the characteristics of sensor. User can select the shutter mode in the ShutterMode under the AcquisitionControl based on your needs.

## Exposure Mode

The frame acquisition process includes exposure and readout. Therefore, according to the overlapping relationship between the exposure time and readout time, the exposure modes include non-overlapped and overlapped.

The exposure mode is only available in some models, please refer to the actual conditions. User can configure the parameter of `OverlapMode` under the `AcquisitionControl`, as shown in the figure below.



Off is non-overlapped; On is overlapped.

### ■ Non-overlapping Exposure

In the non-overlapping mode, camera completes the processes of exposure and data readout before starting the next frame acquisition. The new frame acquisition does not overlap any part of acquisition process of the previous frame. The diagrams of non-overlapping exposure mode in rolling mode and global mode are as follows.

Internal/External trigger non-overlapping exposure in Global mode:

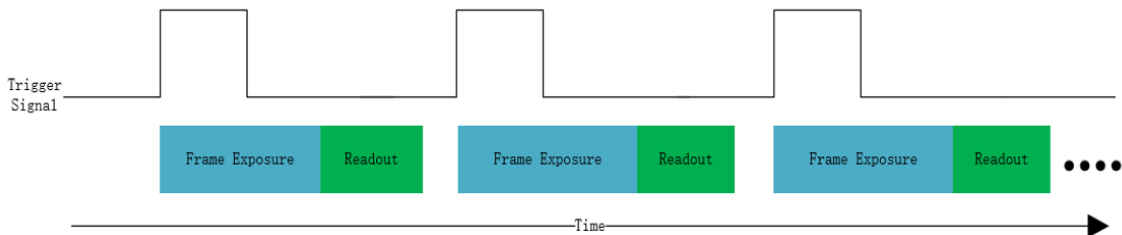

Internal/External trigger non-overlapping exposure in Rolling mode:

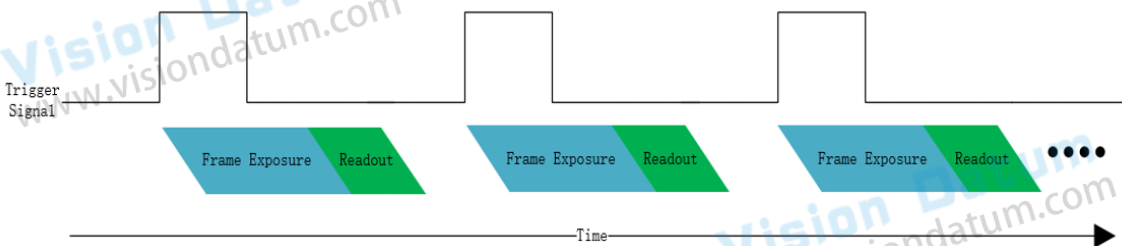

### ■ Overlapping Exposure

In overlapping exposure mode, the camera starts the exposure to the next frame while camera is reading the data of previously acquired image from sensor. The diagrams of overlapped exposure mode in rolling mode and global mode are as follows.

Internal/External trigger overlapping exposure in Global mode:

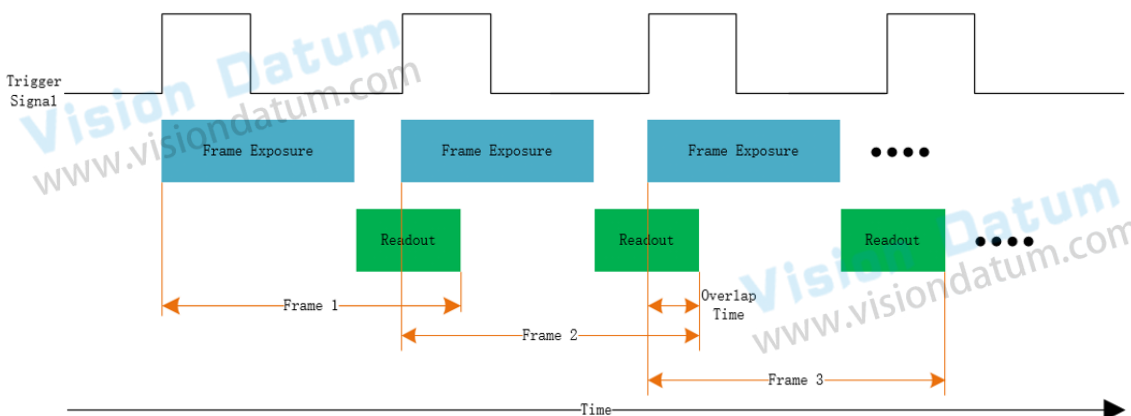

## Exposure Mode

Internal/External trigger overlapping exposure in Rolling mode:

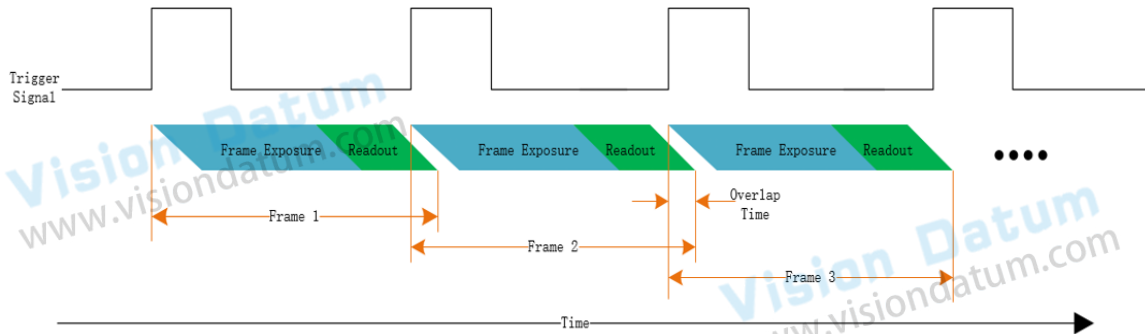

Compared with non-overlapping exposure, the overlapping exposure can reduce the influence of exposure time on the image output time. The overlapping exposure frame cycle is less than or equal to the sum of the exposure time and frame readout time.

## Image Acquisition

The options include SingleFrame, MultiFrame and Continuous.

Acquisition mode description:

Parameter	Parameter Value	Principle
AcquisitionControl > AcquisitionMode	SingleFrame	The camera only acquires one frame of image.
	Continuous	When camera starts image acquisition, it acquires images continuously. Real-time frame rate decides the acquisition frame number per second. You can stop camera image acquisition manually.
	MultiFrame	The number of acquisitions needs to be set in AcquisitionFrameCount (1-255). After the camera starts to capture, you can continuously capture images. The user can manually stop the collection before reaching the set number of times.

When using multi-frame acquisition, the AcquisitionFrameCount option needs to be set additionally. The user selects and enters the appropriate quantity according to the usage requirements.

## Trigger Mode

The external trigger signals types of trigger camera acquisition can be given by software or external device. The trigger mode is divided into SoftwareTrigger (Software trigger) and lineN (Hard trigger).

### ■ Trigger Type

Select FrameStart or AcquisitionStart in TriggerSelector.

- FrameStart: Single frame acquisition, one trigger signal corresponds to one frame.
- AcquisitionStart: continuous acquisition, one trigger can trigger continuous acquisition.

TriggerSelector	AcquisitionStart
TriggerMode	FrameStart
TriggerSoftware	{Command}

After the TriggerMode is set to On, user shall select the trigger source for the AcquisitionStart and send the corresponding trigger signals, and the related parameters of FrameStart should also be configured, the camera can work properly.

### ■ Frame Start

Before using the FrameStart, user shall set TriggerMode in the AcquisitionStart to Off, or set TriggerMode to On and the camera has received the trigger signals. The options in FrameStart include Off and On. It is off by default. When it is off, the camera will acquire images according to the set frame rate, not the trigger signals.

TriggerSelector	FrameStart
TriggerMode	Off

After setting the TriggerMode to On, user shall set the trigger source and send the trigger signals.

TriggerSelector	FrameStart
TriggerMode	On
TriggerSource	Software
TriggerSoftware	Line1
TriggerSoftwareSpeedUp	Line2
TriggerActivation	Line1andLine2
TriggerMixMode	

## Trigger Mode

### ■ Trigger Parameter Settings

#### 1. Trigger Source Setting

The descriptions of trigger source are as follows.

- After setting the TriggerSource to the Software, the Command on the right side of the TriggerSoftware needs to be clicked, and the software trigger command will be generated.

TriggerSelector	FrameStart
TriggerMode	On
TriggerSource	Software
TriggerSoftware	{Command}

- If the TriggerSource is set to the Line1 or Line2, the camera will only respond to the trigger signal from the Line1 or Line2.
- If the TriggerSource is set to the Line1andLine2, the camera will respond to the trigger signal from the Line1 and Line2.



- The trigger sources may vary depending on the device model; therefore, the actual condition shall prevail.
- When the TriggerSource is set to the Line1andLine2, it is Dual Trigger mode. The details of Dual Trigger, please refer to the "Dual Trigger Mode".
- The other parameters related to the TriggerSource, please refer to the "Input Control and Output Control". User can see the properties of AcquisitionStart and FrameStart to achieve the overall control of the image acquisition of camera.

#### 2. Trigger Signal Activation

The descriptions of TriggerActivation are as follows.

- After the TriggerSource is set to the 'Line1' or 'Line2', user can set the TriggerActivation to 'RisingEdge' or 'FallingEdge', as shown in the figure below.

TriggerActivation	RisingEdge
	RisingEdge
	FallingEdge

- After the TriggerSource is set to Line1andLine2, user can configure the valid edges of trigger signals of 'Line1' and 'Line2' in the TriggerMixMode.

TriggerSource	Line1andLine2
TriggerSoftware	{Not Available}
TriggerSoftwareSpeedUp	False
TriggerActivation	RisingEdge
TriggerMixMode	Line1_rise_Line2_rise
TriggerDelay	Line1_fall_Line2_rise
TriggerCacheEnable	Line1_rise_Line2_fall
ExposureMode	Line1_fall_Line2_fall
ExposureTargetBrightness	Line1_fall_Line2_fall

## Trigger Mode

### 3. Trigger Delay

User can configure the parameter TriggerDelay to achieve the delay effect, as shown in the figure below.

TriggerDelay	100.00000 us
--------------	--------------

### 4. Trigger Signal Cache

After enabling the TriggerCacheEnable, camera caches the external trigger signals. The maximum cache capacity is 8. This function is for the instantaneous fluctuations in the frequency of the external trigger signal, as shown in the figure below.

TriggerCacheEnable	False
ExposureMode	True

### 5. Light Trigger Delay

This function is only available after the FrameStart is enabled, and it delays the trigger signals of fill light. The improper value of the LightTriggerDelay will cause the abnormalities of light filling.

## Trigger Mode

### ■ Dual Trigger Mode

The trigger source of Dual Trigger can be Line1 or Line2. The dual trigger mode can be effective only when the trigger mode is enabled, and the ExposureMode is set to Timed. This mode should be used in conjunction with the TriggerMixMode.

#### Procedure

Step 1 Set the TriggerMode under the AcquisitionControl to On.

Step 2 Set the TriggerSource to Line1andLine2.

TriggerMode	On
TriggerSource	Line1andLine2
TriggerSoftware	{NotAvailable}
TriggerSoftwareSpeedUp	True
TriggerActivation	RisingEdge
TriggerMixMode	Line1_rise_Line2_rise

Step 3 Set the TriggerMixMode to Line1\_rise\_Line2\_rise. The sequence diagram is as follows.

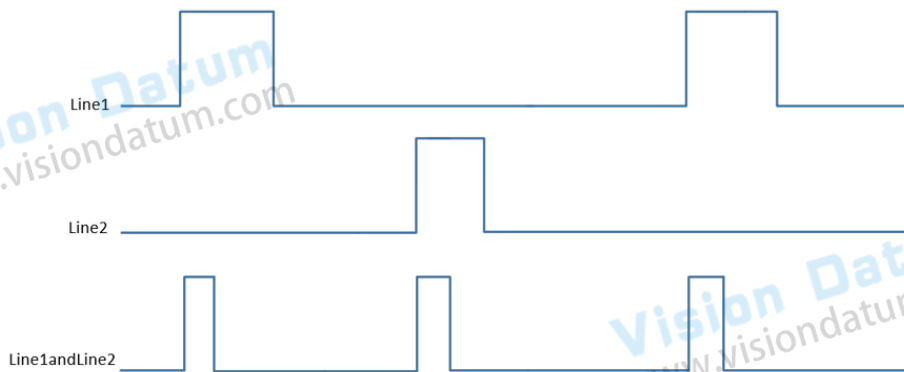

### ■ Burst Mode

The BurstMode is a function of making image acquisition faster and perform data transmission according to the bandwidth rate. After disabling this function, the acquisition frame rate of camera equals to the bandwidth transmission rate. When theoretical frame rate (Resulting Frame Rate) is limited by the network bandwidth, user can enable the burst mode to increase the acquisition rate, the sensor will acquire images at a higher frame rate, and the images will be stored in the DDR and be transmitted according to the transmission rate of bandwidth. If the sensor keeps acquiring images at the higher frame rate after enabling the burst mode, when the stored image capacity is greater than the DDR capacity, the image stored before will be overwritten.

User can set the BurstMode under the AcquisitionControl to On. This function is only available when the trigger mode is enabled.

BurstMode	On
TriggerSelector	FrameStart
TriggerMode	On

## Input Control and Output Control

### Line Selection and Line Mode

There are three I/O lines available for the camera, namely line0 (opto-isolated output), line1 (opto-isolated input), and line2 (opto-isolated input or output).

LineSelector	Line0
LineMode	Line1
LineInverter	Line2

The line0 has only the output mode. The line1 has only the input mode. The line2 has the input mode and output mode.

LineSelector	Input
LineMode	Output

### Level Inversion and Status Display

User can invert the level of trigger input signal or output signal in LineInverter, and the signal of each line can be set separately. When user set the LineInverter to True, the level of trigger input signal or output signal will be inverted, which means the high-level signal will be inverted into lowlevel signal. The LineInverter is False by default.

LineInverter	False
LineStatus	True

When the input signal and output signal of the selected line is low level, the LineStatus will be False; When the input signal and output signal of the selected line is high level, the LineStatus will be True. Line status is as shown in the following figure.

LineStatus	False
------------	-------

The LineStatusAll can obtain the status of all lines, and display it in the LineStatus. The status display of all lines is as shown in the figure below.

LineStatusAll	4
---------------	---



The bit0 represents the displayed status is of line0; bit1 represents the displayed status is of line1; bit2 represents the displayed status is of line2.

## Input Control and Output Control

### Output Line Signal Source Setting

User can select the signal source of output line in the LineSource . When the LineMode is set to input, the LineSource is grayed out. The options of LineSource are shown in the figure below.

Typically, when the line0 or line2, the output line, is set to the output mode, the LineSource is used to define the type of light filling signals.

LineSource	ExposureActive
ExposureActiveMode	FrameTriggerWait
ExposureActiveValue	Timer0Active
StrobeStart	AcquisitionTriggerWait
StrobeLineDuration	UserOutput0
StrobeLineDelay	FlashWindow
LineFormat	SoftTriggerActive
LineDebouncerTimeAbs	HardTriggerActive
UserOutputSelector	
UserOutputValue	

- **ExposureActive:** The signals will be pulled up or down in accordance with the signals that control the exposure of sensor. This means that when sensor starts exposure, the signals are pulled up; when sensor stops exposure, the signals are pulled down.
- **FrameTriggerWait:** The output signals are effective only when the TriggerSelector is set to FrameStart, and the Trigger Mode is set to On. The default high level is pulled down when the external trigger signal is received. After the corresponding number of frames are outputted, the low level is pulled up, as shown in the figure below.

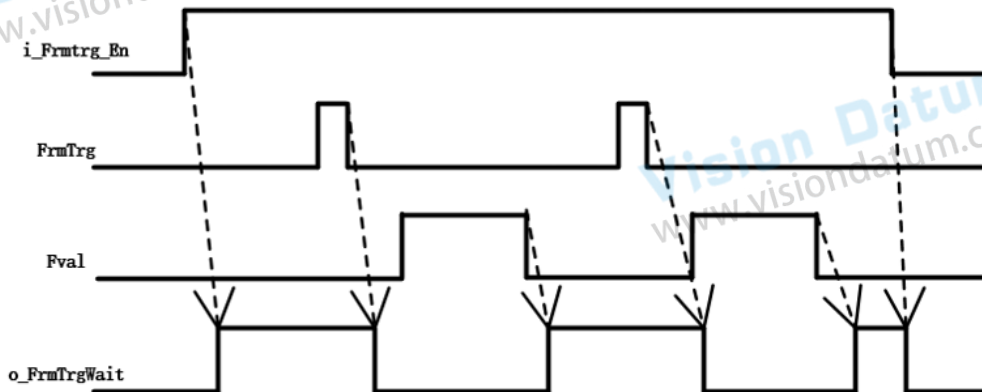

- **Timer0Active:** To output the corresponding pulse signals according to the user-defined timer. The detailed information about timer, please refer to the "Timer".
- **AcquisitionTriggerWait:** This output signal is effective only when the Trigger Selector is set to AcquisitionStart, and the Trigger Mode is set to On. When starting streaming, the default high level is pulled down when the external trigger signal is received. After the command of AcquisitionStop is received, the low level is pulled up, as shown in the figure below.

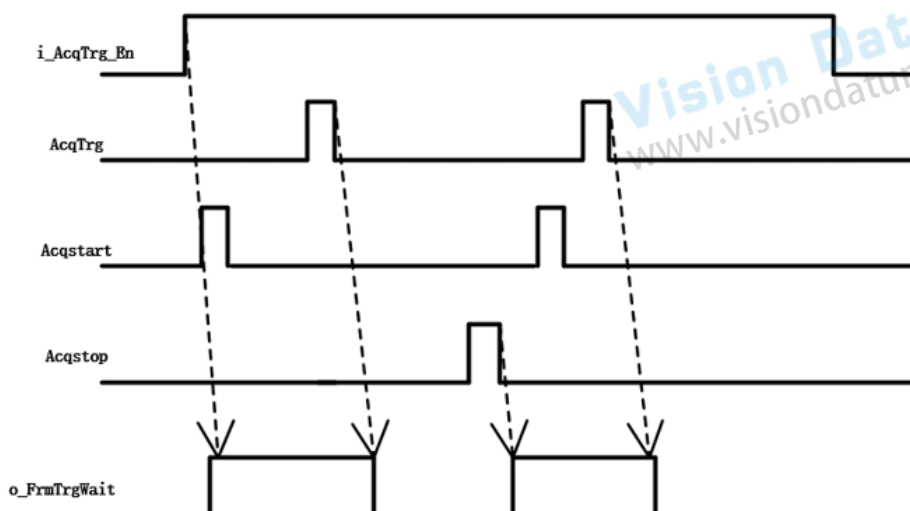

## Input Control and Output Control

● UserOutput0/UserOutput1: The output status of the user-defined signals. The default status is low, and it should be used with the parameters of User OutputSelector and UserOutputValue. The output status is inversed when the UserOutputValue is set to True.



Line0 corresponds to the UserOutput0 ; Line2 corresponds to the UserOutput1 when Line2 is defined as the output.

● FlashWindow: The camera outputs the pulse signals of all lines which are in the exposure period in the sensor during frame acquisition according to the calculation. This function is available only in the rolling shutter mode.

The signal output diagram of Flashwindow when the ShutterMode is set to Rolling is as follows.

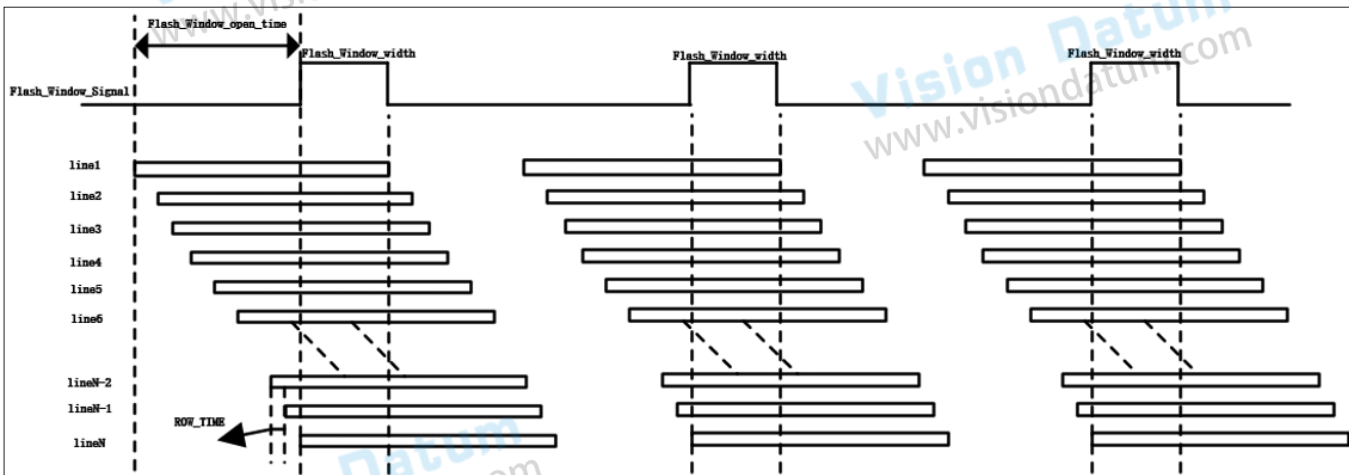

The signal output diagram of Flashwindow when the ShutterMode is set to GlobalResetRelease is as follows.

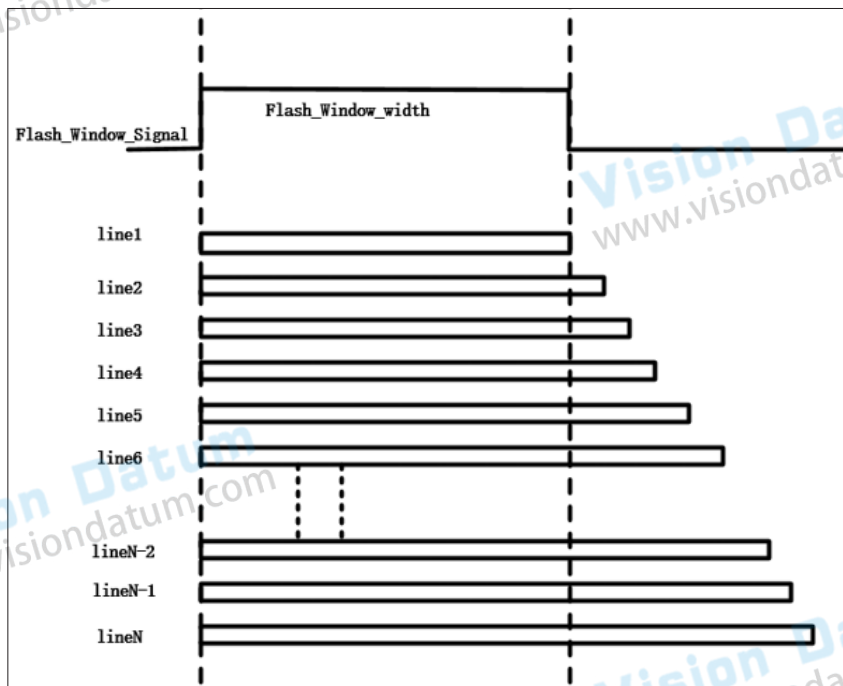

● SoftTriggerActive: When the signals of StrobeStart take effect, it outputs the corresponding pulse signals to the external device through I/O interface according to the generated event.

● HardTriggerActive: When the hardware trigger signals take effect, it outputs the corresponding pulse signals to the external device through I/O interface according to the generated event.



The relevant variables and formulas are described in the table below. For detailed information about the Strobe configurations, please refer to "Strobe Module".

Variable	Formula
Flash_Window_open_time	$ROW\_TIME \text{ (row readout time)} \times (ROI \text{ Height} - 1)$
Flash_Window_width	$Exposure \text{ time} - ROW\_TIME \text{ (row readout time)} \times (ROI \text{ Height} - 1)$
Min.exposure time for flash window in rolling shutter mode	$Exposure \text{ time} > ROW\_TIME \text{ (row readout time)} \times (ROI \text{ Height} - 1)$

## Input Control and Output Control

### ■ Strobe Module

The related parameters of strobe module are as shown in the figure below.

StrobeStart	{Command}
StrobeLineDuration	0.00
StrobeLineDelay	0.00

- After the LineSource is set to the SoftTriggerActive, when you click the Command in StrobeStart, it will generate an event of SoftTriggerActive, and then output the strobe signals of the corresponding pulse to the external devices through I/O interface according to the configured values of the StrobeLineDuration and StrobeLineDelay, as shown in the figure below.



The value range of StrobeLineDuration and StrobeLineDelay is 0us~1000000us.

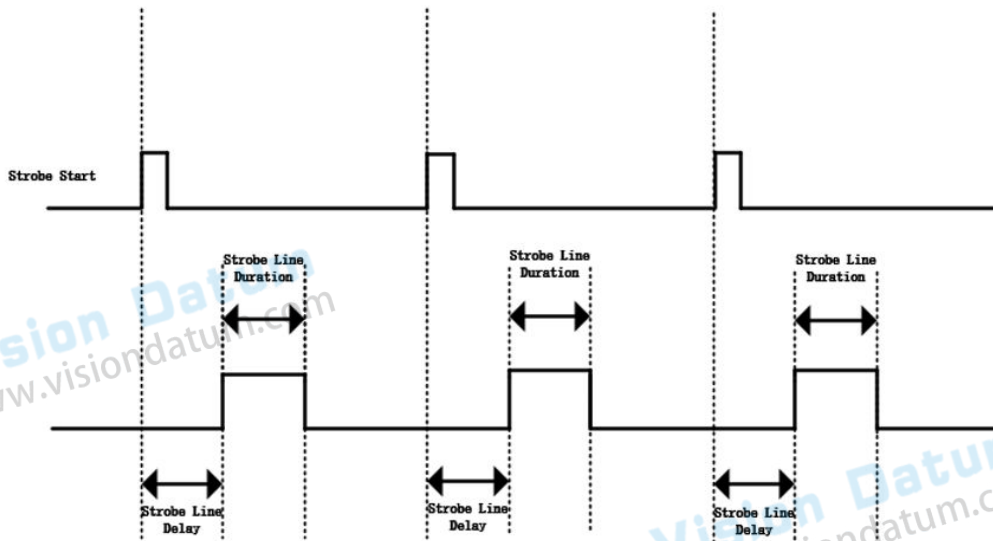

- After the LineSource is set to the HardTriggerActive, the StrobeStart will be grayed out.

When the input signals of hardware trigger (Line1 or Line2) take effect, it will generate an event of HardTriggerActive, and then output the strobe signals of the corresponding pulse to the external devices through I/O interface according to the configured values of the StrobeLineDuration and StrobeLineDelay.

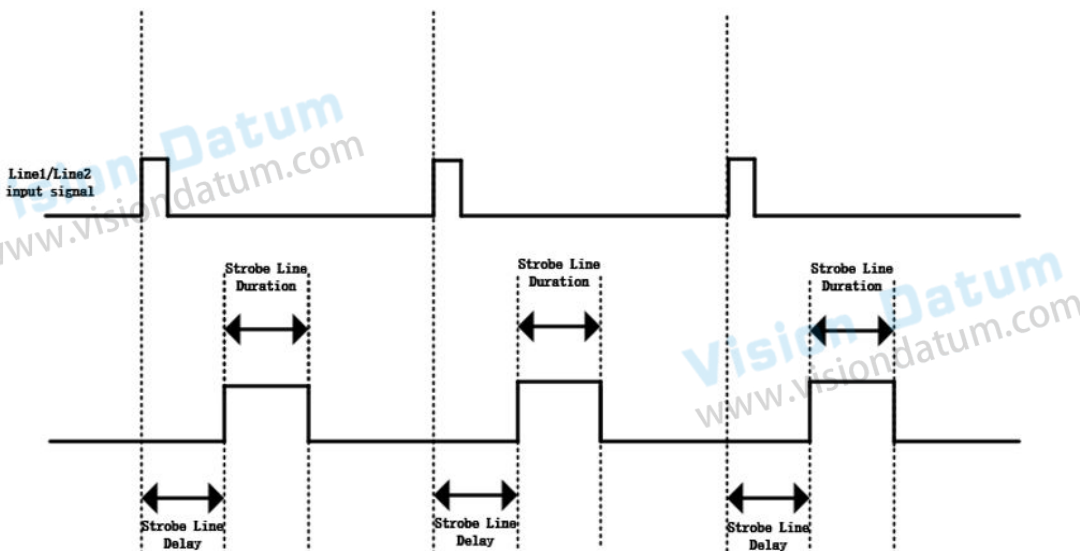

## Input Control and Output Control

### ■ Fill Light Mode and Time Setting

User can select the light mode in the ExposureActiveMode , and this function is available only when the LineSource is ExposureActive.

ExposureActiveMode	ExposureActiveAhead
ExposureActiveValue	ExposureActiveAfterward
ExposureActiveValue	0



- The ExposureActiveAhead refers to light filling being performed in advance, while the ExposureActiveAfterward refers to the light filling is performed later.
- User can set the advance time or delay time in the ExposureActiveValue. The parameter range is 0us~10000us, and the default value is 0.

The following diagrams are the sync light filling, advance light filling and delayed light filling.

Sync light filling:

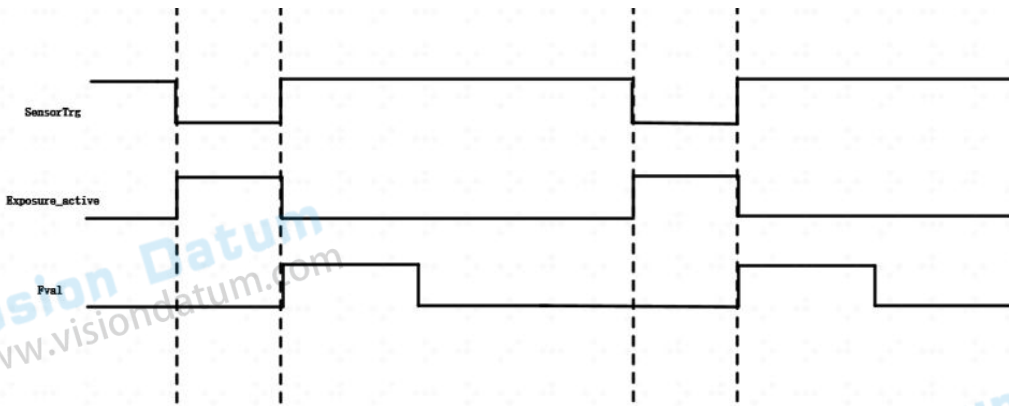

Advance light filling:

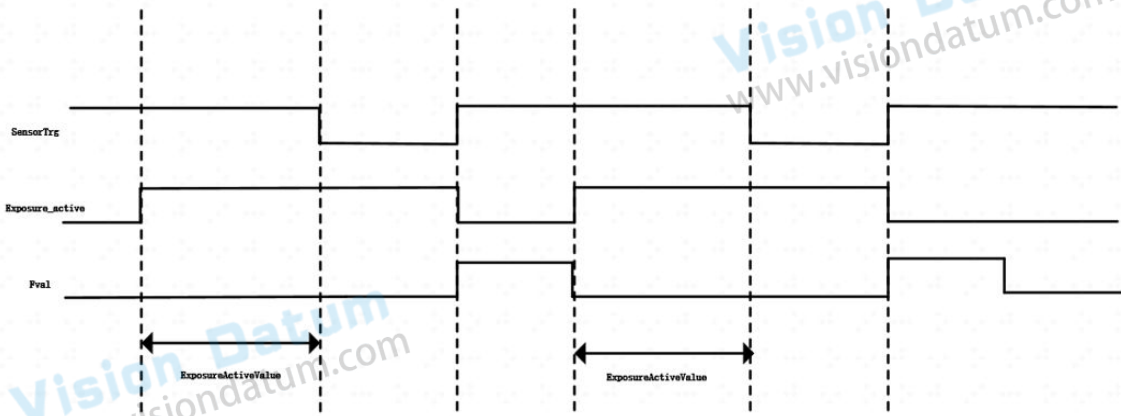

Delayed light filling:

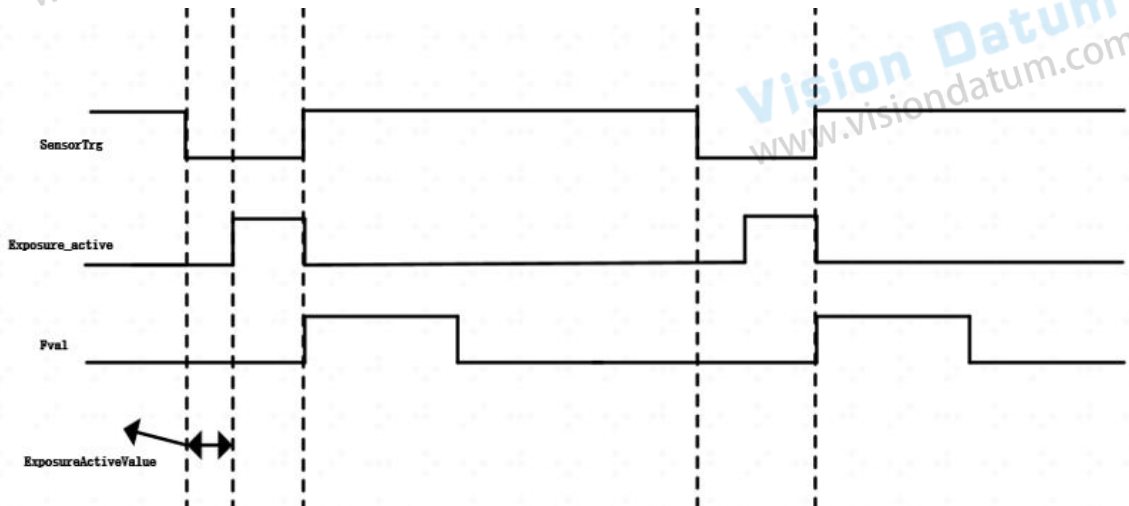

## Input Control and Output Control

### ■ Hardware Line Type and Filtering

#### 1. Hardware Line Definition

When the LineSelector is set to the Line0 or Line1, the LineFormat is defined as the OptoCoupled automatically, as shown in the figure below.

LineFormat	OptoCoupled
------------	-------------

When the Line Selector is set to the Line2, LineFormat is defined as the TTL automatically which can be configured as input or output.

LineFormat	TTL
------------	-----

#### 2. Filtering

User can set the parameters of filtering in the LineDebouncerTimeAbs . This function is effective only when the LineMode is set to input, which means that the LineSelector is set to line1, or the LineSelector is set to line2 and in the input mode.

The signal glitches in the external trigger signals may cause the false triggering of camera. The parameter LineDebouncerTimeAbs can filter out the signal glitches that the cameras do not need.



User can find the LineDebouncerTimeAbs under the DigitalIOControl. The value range is  $0\mu\text{s}\sim 1000000\mu\text{s}$  (0s~1s).

LineDebouncerTimeAbs	20.00000 us
----------------------	-------------

When the time value of LineDebouncerTimeAbs is greater than that of trigger signals, the trigger signals will be ignored. The timing sequence diagram is as follows.

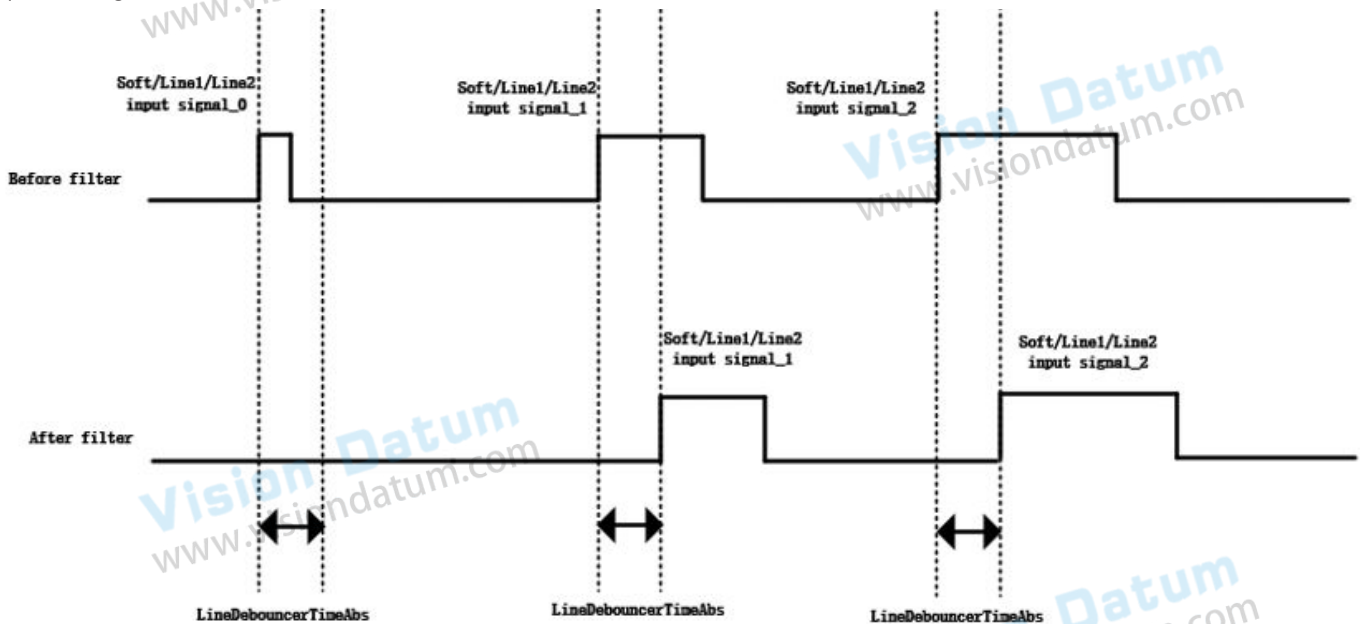

## Input Control and Output Control

### ■ User Output Selection

The parameters UserOutputSelector is effective only when the LineMode is set to output, which means that the LineSelector is set to line0, or the LineSelector is set to line2 and in the output mode.

The options of UserOutputSelector include UserOutput0 and UserOutput1.



- When the LineSelector is line0 and the LineSource is UserOutput0, the UserOutput0 is the userdefined output signals of line0.
- When the LineSelector is line2 and the LineSource is UserOutput1, the UserOutput1 is the userdefined output signals of line2.

UserOutputSelector	UserOutput0
UserOutputValue	UserOutput1
UserOutputValueAll	0

The default value of UserOutputValue is False. When it is set to True, the user-defined value will be performed the negation operation, that is, '0' becomes '1'. The UserOutputValue is as shown in the figure below.

UserOutputValue	False
UserOutputValueAll	True

The UserOutputValueAll can obtain the status of all user-defined signals, and implement numeric display based on 2-bit binary encoding. The UserOutputValue is as shown in the figure below.



The bit0 refers to the status of UserOutput0; bit1 refers to the status of UserOutput1.

UserOutputSelector	UserOutput0
UserOutputValue	False
UserOutputValueAll	0

## Exposure

The exposure time can be configured through the modes of Timed and TriggerWidth in the ExposureMode.

ExposureMode	Timed
ExposureTargetBrightn...	TriggerWidth
ExposureAuto	(not available)
ExposureTime	4,000.00000 us
ResultingExposureTime	4,000.00000 us

- Timed: The exposure time is controlled by the set values in the ExposureAuto and ExposureTime.
- TriggerWidth: The exposure time is controlled by the duration of level signal. In this mode, the parameters of ExposureAuto and ExposureTime will be invalid.



The TriggerWidth mode is available when the TriggerMode is on, and the TriggerSource is Line1 or Line2.

The exposure modes are Off , Once, and Continuous. The descriptions of exposure modes are in the list below.

Parameter Value	Principle
Off	To adjust the exposure based on the set value in the ExposureTime.
Once	Run the auto exposure once for a period and then stops based on the environment.
Continuous	Automatically and continuously adjust the exposure according to the environment.

ResultingExposureTime is for displaying the current exposure time of camera in real time.



The range of exposure time value may vary depending on the device model, please refer to the corresponding technical specifications.

## Frame Rate

Frame rate is an important metric of a camera, and it represents the number of images the camera outputs per second. The higher the frame rate, the smoother the video streaming; the lower the frame rate, the more stuck the video streaming, and the more obvious the jumping change of image content.

ResultingFrameRateAbs refers to the supported frame rate of camera based on the current parameters and transmission rate.

ResultingFrameRateAbs	19.20534 Hz
-----------------------	-------------

### Factors Affecting Frame Rate

The following 5 factors determines the camera's frame rate in real-time.

- **Resolution:**The higher resolution means that one frame of image includes more pixels, larger data amount and lower frame rate of the transmission.
- **Exposure Time:**The exposure process as a part of imaging can be controlled by users. The longer the exposure time, the lower the frame rate.
- **Bandwidth:**The bandwidth determines the upper limit of the frame rate. The greater the bandwidth, the more data can be transmitted per unit time, resulting in a higher frame rate.
- **Pixel Format:**The byte size of the pixels may vary depending on the different image formats. The larger the byte size, the larger the data amount and the lower the frame rate of camera.
- **Lossless Compression:**After enabling the lossless compression, the video streaming data amount can be reduced, which can increase the frame rate to a certain extent.



- The cameras give priority to the exposure time, which means that if the exposure time is greater than the reciprocal of frame rate, it will give priority to reducing the frame rate instead of limiting the maximum exposure time.
- If the lossless compression function is enabled, the images after performing lossless compression must be analyzed with the iCentral.

### Configuring Frame Rate

The camera can also manually control the real-time frame rate. The specific steps are as follows:

1. Click AcquisitionControl > AcquisitionFrameRate, enter Acquisition Frame Rate according to actual demands, and enable AcquisitionFrame RateControlEnable.

AcquisitionFrameRate	1.00000 Hz
AcquisitionFrameRateEnable	True
	False
	True

2. Set the AcquisitionFrameRateEnable under the AcquisitionControl to True.

- AcquisitionFrameRate means frame capture rate.
- ResultingFrameRateAbs means allow the maximum acquisition frame rate.

\_If the AcquisitionFrameRate is smaller than ResultingFrameRateAbs, the camera acquires images according to the AcquisitionFrameRate.

\_If the AcquisitionFrameRate is larger than ResultingFrameRateAbs, the camera acquires images according to the ResultingFrameRateAbs.

## Multi-Frame Average

The multi-frame average performs average on multiple images produced by sensor to improve the image quality. After enabling this function, the frame rate will be reduced to the previous 1/N. The 'N', an integer, is the number of the images which are averaged. The related parameters of multiframe average are shown in the figure below.

AVGNum	4.00
AVGEnable	True

## Lossless Compression

After enabling the lossless compression, the camera performs the lossless compression on the acquired images according to the complexity of the scene to reduce the data amount transmitted on the network. Therefore, it can increase the maximum transmission rate while the transmission bandwidth remains unchanged.

This function can be used with burst mode to further improve the instantaneous frame rate of the camera. The related parameters of lossless compression are shown in the figure below.

Compress	On
CompressionBandwidthMode	Compression
<input checked="" type="checkbox"/> AutoFunctionControl	Burst

## Packet Size

The packet size indicates the size of data packet in stream channel between the camera and host PC. User can configure the packet size properly to optimize the network performance which can reduce the transmission delay and improve the throughput ensuring the reliability of data transmission.

The parameter of GevSCPSPacketSize is under the TransportLayerControl. During camera initialization, the packet size negotiation will be performed between PHY chip of camera and the network card of host PC, and the negotiation result will be default value of the GevSCPSPacketSize.

GevSCPSPacketSize	8,040
-------------------	-------



- The maximum packet size of standard Ethernet frame is 1500 bytes; therefore, when the value needs to be larger than the 1500, the jumbo frame function should be enabled.
- For high-latency network, user can reduce the packet size to reduce the transmission delay; for high-bandwidth network, user can increase the packet size to reduce the data transmission intensity and improve the throughput.

## Packet Interval

User can enable this function to control the bandwidth at which the camera transmits the image stream data. The packet interval means that it inserts the idle clocks between the adjacent data packets transmitted in the stream channel, and each clock creates an 8ns interval. Increasing the packet interval can reduce the occupancy on the network bandwidth from the camera, and probably lower the acquisition rate of the camera.

$$T_{delay} = Delay\_pkt * 8ns$$

T\_delay means the packet delay time; Delay\_pkt means the packet interval, i.e., SCPD.

User can set the packet interval in the GevSCPD under the TransportLayerControl.

AdaptiveStreaming	On
RealSCPD	0
GevSCPD	0

User also can set the AdaptiveStreaming to On to optimize the data transmission process. After configuring this parameter, the value displayed in the RealSCPD is the actual SCPD value of the device.

## Frame Transmission Delay

User can delay the sending time of the first packet of image data in the GevSCFTD, as shown in the figure below. It is 0 by default, and the value range is 0ns~125000000ns.

GevSCFTD	0
----------	---

If one switch is connected with multiple cameras at the same time, when these cameras send GVSP stream data packets to the switch simultaneously after receiving the trigger signals at the same time, the network card will bear much instantaneous network pressure. If the configuration of network card is not high enough for this situation, the retransmission and drop frames may occur.

User can use GevSCFTD to set different FTD value for every camera to stagger the data packet sending times to reduce the instantaneous network pressure.

Usually, we recommend you set the FTD value as the size of a gvsp packet. Take GevSCPSPacketSize is 8044 as an example, if one switch is connected with four cameras including Camera A, Camera B, Camera C and Camera D, the GevSCFTD values of these four cameras should be 0, 8044, 16088 and 24132, and the GevSCPD value of four cameras should be 24132, as shown in the figure below.

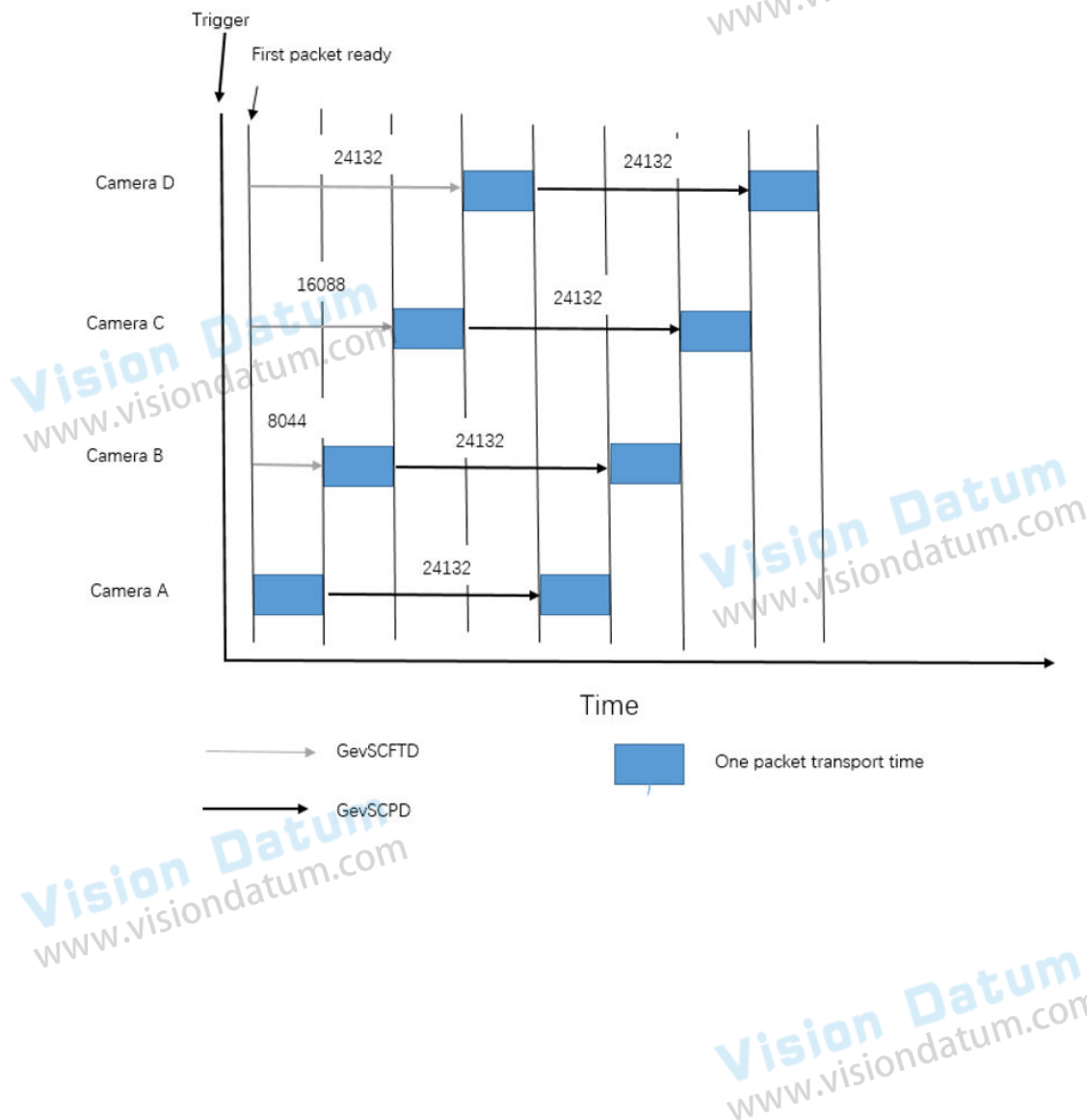

## CHAPTER 5 I/O Electrical Feature and Wiring

### Opto-Isolated Input

#### ■ Opto-Isolated Input Circuit

Since the optocoupler is one-way transmission, it can realize the one-way signal transmission, so that the input terminal and the output terminal are completely electrically isolated, the output signal has no effect on the input terminal, and the anti-interference ability is strong and the work is stable.

The Line1 opto-isolated input circuit in camera I/O control is shown below.

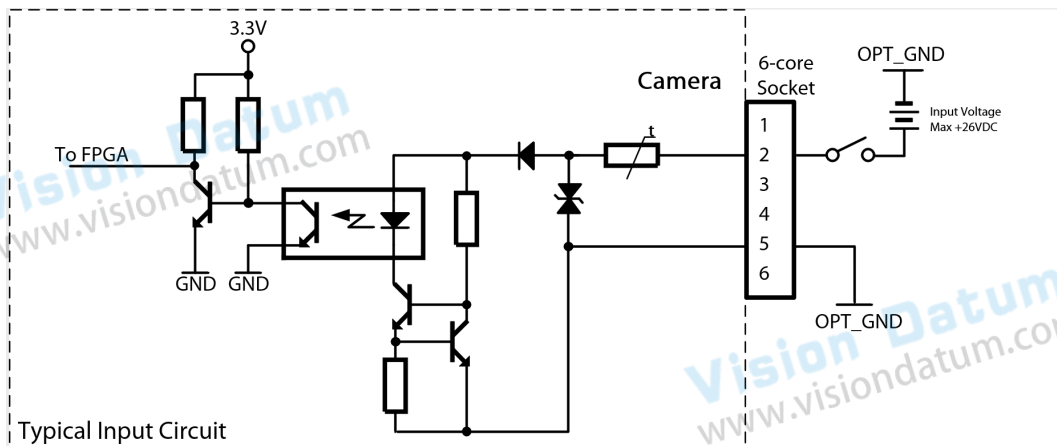

The description of opto-isolated input circuit and the internal circuit diagram of opto-isolated input interface are as follows.

Input Voltage	Description
+26VDC	Extreme voltage. The input voltage cannot exceed the value. Otherwise, the device might be damaged.
+0~+24VDC	Security working voltage range for I/O input.
+0~+1.4VDC	Logic 0.
>+1.4V~+2.2VDC	The input status changes and the logic status is uncertain within this voltage range.
>+2.2VDC	Logic 1.



The input voltage is the potential difference between the opto-isolated input (Line1) and opto-isolated signal ground (OPT\_GND).

## Opto-Isolated Input

### Input Current and Input Voltage

The relationship between the input current and input voltage of opto-isolated input interface is as follows.

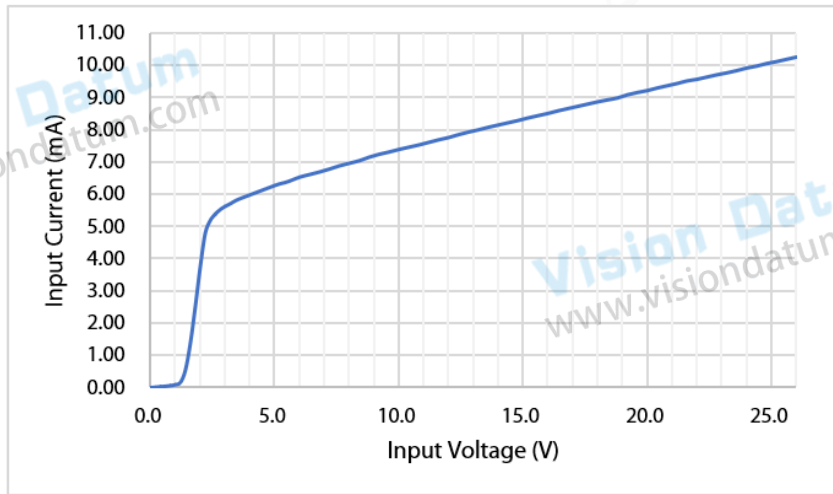

Values in the line chart are obtained at an environmental temperature of 25° C (77° F). Therefore, the actual values may vary among the different models of camera in the different environments.

### Trigger Delay and Input Signal Amplitude

Signal delay diagram of opto-isolated input interface is as follows; the relationship between the input signal amplitude of opto-isolated input interface and the delay is described in the table below.

- Rising Edge Trigger Delay: The delay time from the 90% of external input signal amplitude to the 90% of FPGA pins input signal amplitude.
- Falling Edge Trigger Delay: The delay time from the 10% of external input signal amplitude to the 10% of FPGA pins input signal amplitude.

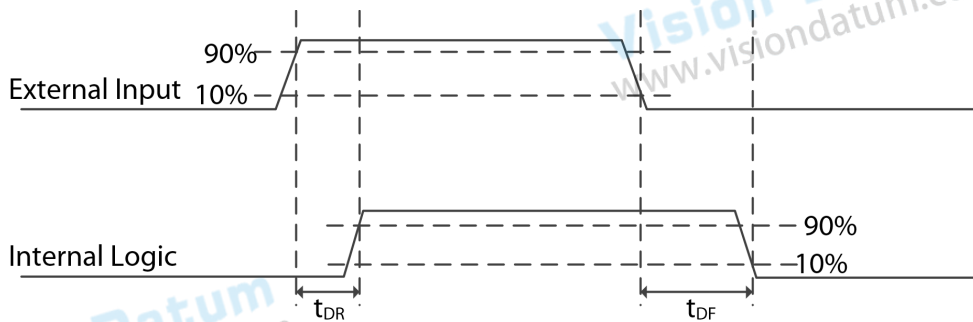

Input signal amplitude (Vp-p)	Rising Edge Trigger Delay tDR (us)	Falling Edge Trigger Delay tDF (us)
3.3	3.99	20.80
5	3.80	21.16
9	3.61	21.47
12	3.19	21.47
24	3.50	21.83



- The trigger delay measurement measures the delay value from external opto-isolated input interface to the FPGA input pins, which means the internal logic delay of the FPGA is not included.
- The shortest input positive pulse of opto-isolated input interface is 1.02 μs when the pulse amplitude is 3.3 V; the shortest input negative pulse of opto-isolated input interface is 20.97 μs.
- Values in the table are obtained at an environmental temperature of 25° C (77° F). Therefore, the actual values may vary among the different models of camera in the different environments.



- Do not apply the voltage on the input terminals which exceeds the allowed maximum value.
- Do not replace the fuse by yourself. If the fuse blows due to the abnormalities, such as short circuit, please contact our after-sales to provide the maintenance service.

## Opto-Isolated Output

### Opto-Isolated Output Circuit

The description of opto-isolated output circuit and the internal circuit diagram of opto-isolated output interface are as follows.

Voltage	Description
+26VDC	Extreme voltage. The input voltage cannot exceed the value. Otherwise, the device might be damaged.
<+3.3VDC	This voltage range may result in an error on I/O output.
+3.3~+24VDC	Security working range for I/O output.

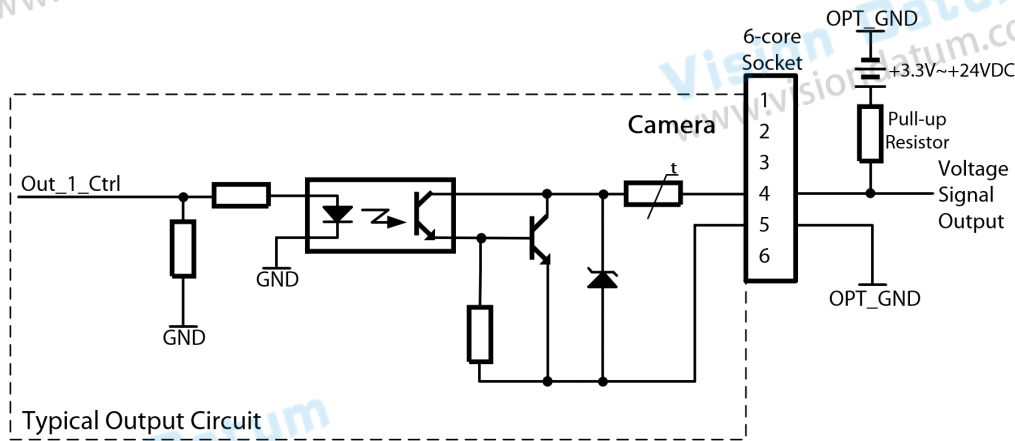

### Output Delay and External Current Voltage

In some cases, an external pull-up resistor to the external power is needed to produce high-level output. The value of pull-up resistor is related to the external device and application scenarios, but the value cannot exceed the allowed maximum current of opto-isolated output interface. The larger the resistance value, the smaller the optocoupler conducting voltage drop, the more slowly the output wave changes and the weaker the control over external devices. For more details, please refer to the application document AN15 Industrial Camera Opto-isolated Output Pull-up Resistor Selection Introductions.

The maximum current of opto-isolated output is 50 mA. The signal delay diagram of opto-isolated output is as follows.

**i** If the external pull-up resistance is adopted, the pull-up resistance and voltage shall be 1 kΩ at 3.3 V, 1 kΩ at 5 V, 2.4 kΩ at 12V, 4.7 kΩ at 24V.

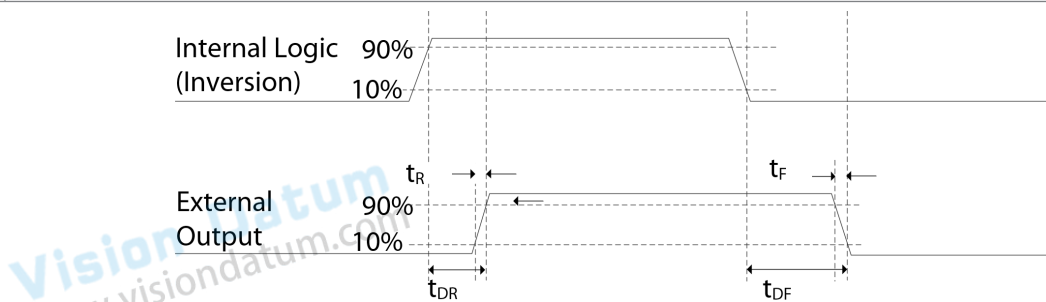

The relationship between rising/falling time and rising/falling edge delay time when the pull-up resistance is 1kΩ are shown in the list below.

External Voltage (V)	Rising Time tR (us)	Falling Time tF (us)	Rising Edge Trigger Delay tDR (us)	Falling Edge Trigger Delay tDF (us)
5	19.70	3.20	39.9	8.06
12	24.06	5.22	44.8	11.8
24	30.11	8.10	44.8	53.2

**i**

- The output delay measurement measures the delay value from the FPGA output pins to the opto-isolated output pins, which means the internal logic delay of the FPGA is not included.
- Rising Time: The time for the output pulse to rise from 10% to 90%. Falling Time: The time for the output pulse to fall from 90% to 10%.
- Rising Edge Trigger Delay: The time from 10% of internal logic voltage to 90% of the output pulse voltage. Falling Edge Trigger Delay: The time from 90% of internal logic voltage to 10% of the output pulse voltage.
- Values in the line chart are obtained at an environmental temperature of 25° C (77° F). Therefore, the actual values may vary among the different models of camera in the different environments.

## Opto-Isolated Output

### Output Conducting Voltage Drop and Output Current

The relationship between the opto-isolated conducting voltage drop and output current is described in the figure below.

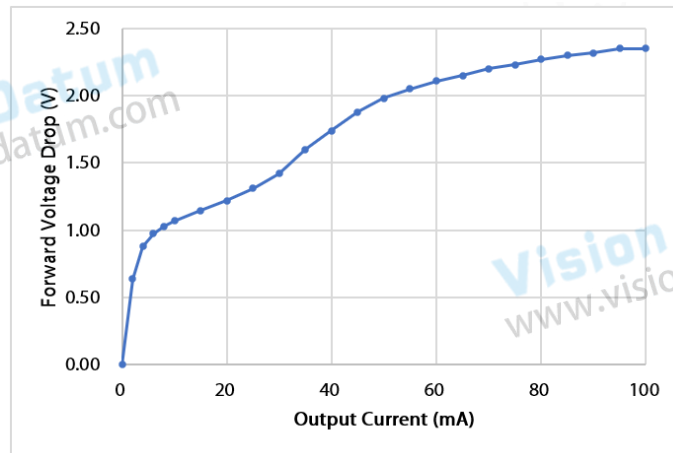

- The value of conducting voltage drop is the voltage difference between the OPT\_OUT (LINE0) and OPT\_GND in the state of conducting.
- The maximum conducting voltage drop of opto-isolated output is 2.35V. This result is obtained under the maximum output current 100mA.
- Values in the figure are obtained at an environmental temperature of 25° C (77° F). Therefore, the actual values may vary among the different models of camera in the different environments.

### Opto-isolated Interface as Transistor Output

The transistor output can be isolated with the internal circuit by using the opto-isolator. Therefore, the transistor output can be used as NPN output or PNP output. If the opto-isolator is as the PNP output, the opto-isolated input (Line1) is unavailable. NPN output and PNP output are as shown in the following figure.

#### ● Opto-isolated interface as NPN output

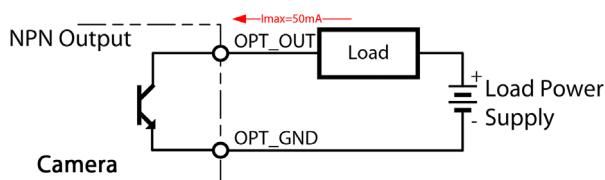

#### ● Opto-isolated interface as PNP output

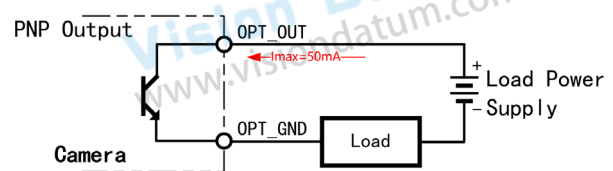

**⚠** After enabling this method, opto-isolator input (LINE1) is unavailable.

- Do not apply the voltage or connect load on the output terminals of opto-isolator which exceeds the allowed maximum value 50 mA.
- Do not replace the fuse by yourself. If the fuse blows due to the overcurrent, such as short circuit, please contact our after-sales to provide the maintenance service.
- To drive the inductive load using camera output signals, such as relay, please use relay with built-in flyback diodes, or use common relay and add the flyback diodes. Otherwise, it may cause damage on the output interface. The figure below gives an example of a suppression circuit for DC inductive load. In most cases, the additional diodes A is sufficient, but if you request a faster shutdown speed, we recommend to add a Zener diode B to meet the current requirement of output circuit.

#### ● Suppression circuit of DC inductive load

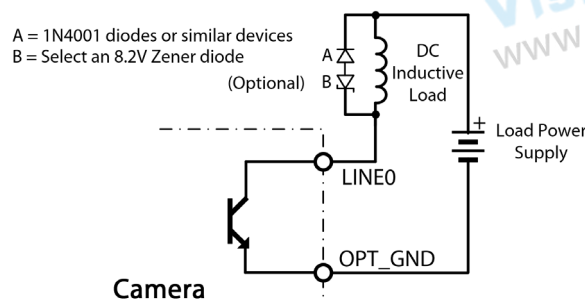

Do not directly connect the opto-isolated output interface of camera with to the tungsten lamp. Because the inrush current at the moment when the tungsten lamp is turned on is 10 times to 15 times its steady-state current, which exceeds the allowed maximum current of opto-isolated output interface. We recommend you use the replaceable plug-in intermediate relay, or add the surge limiter.

## Configurable GPIO

### GPIO as Input

When GPIO is defined as the input, the input voltage description is as follows.

Voltage	Description
+26.0VDC	Extreme voltage. The input voltage cannot exceed the value. Otherwise, the device might be damaged.
+0~+24VDC	Safe operating voltage input range (minimum 3.3 VDC when an external pull-up resistor exists).
+0~+0.8VDC	Logic 0
>+0.8~+2.2VDC	The input status changes and the logic status is uncertain within this voltage range.
2.2VDC	Logic 1

The relationship between the sink current and the external input voltage when GPIO is defined as the input is as follows.

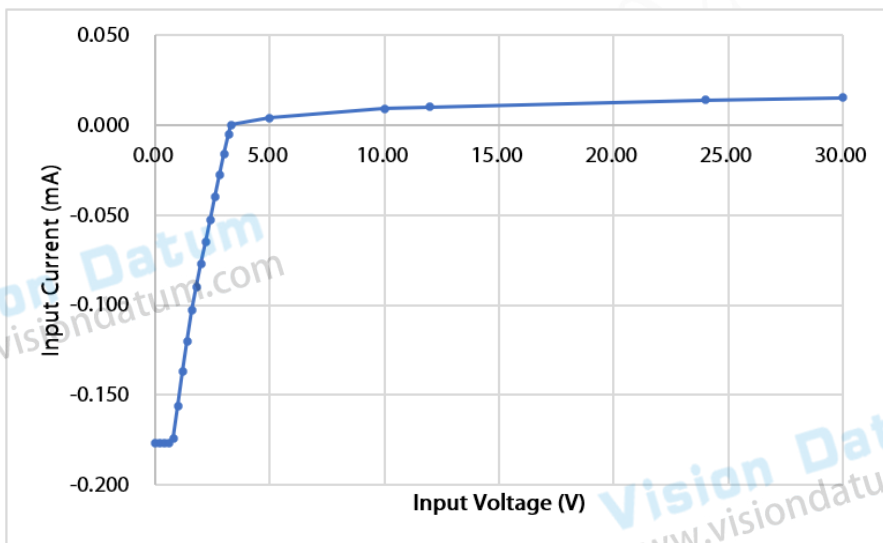

- Values in the line chart are obtained at an environmental temperature of 25° C (77° F). Therefore, the actual values may vary among the different models of camera in the different environments.
- The maximum sink current of GPIO input is 15  $\mu$ A. This value is measured when the external input voltage is 30 V.

### GPIO input signal amplitude versus trigger delay

GPIO input signal amplitude versus trigger delay is as follows.

Input signal amplitude (Vp-p)	Rising Edge Trigger Delay tDR (us)	Falling Edge Trigger Delay tDF (us)
3.00	6.783	0.339
5.00	6.563	0.200
9.00	6.164	0.106
10.00	6.416	0.960

- The trigger delay measurement measures the delay value from external GPIO interface to the FPGA input pins, which means the internal logic delay of the FPGA is not included.
- The shortest input positive pulse is about 20  $\mu$ s (typical value) supported by the GPIO input; the shortest input negative pulse is about 2  $\mu$ s (typical value) supported by the GPIO input.
- The delay time of GPIO interface is less than that of the opto-isolated interface.

## Configurable GPIO

### GPIO as Output

When GPIO is defined as the output, the output voltage description is as follows.

Voltage	Description
+26VDC	Limiting voltage. Output voltage cannot exceed the limit. Otherwise, the device might be damaged.
+3.3~+24VDC	The security working voltage range in output mode
<3.3VDC	Possible error on I/O output.

Up to 50 mA sink current when the GPIO port is used as output. The internal circuit diagram when GPIO is defined as the output is as follows.

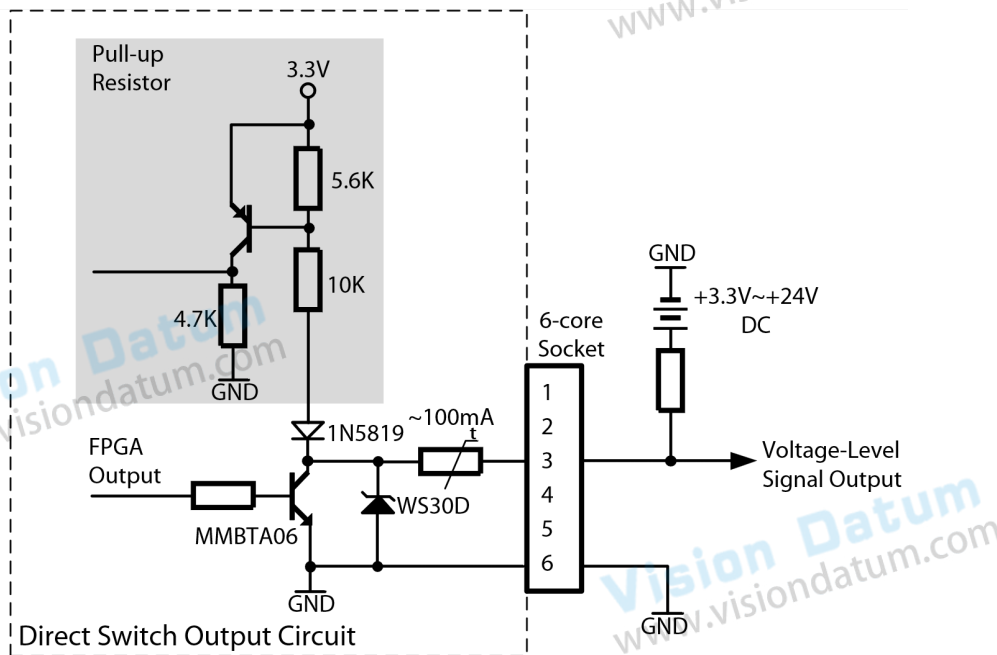

The relationship between the GPIO output conducting voltage drop (the voltage drop between the GPIO and GND) and the output current (the current flowing into the GPIO pins).

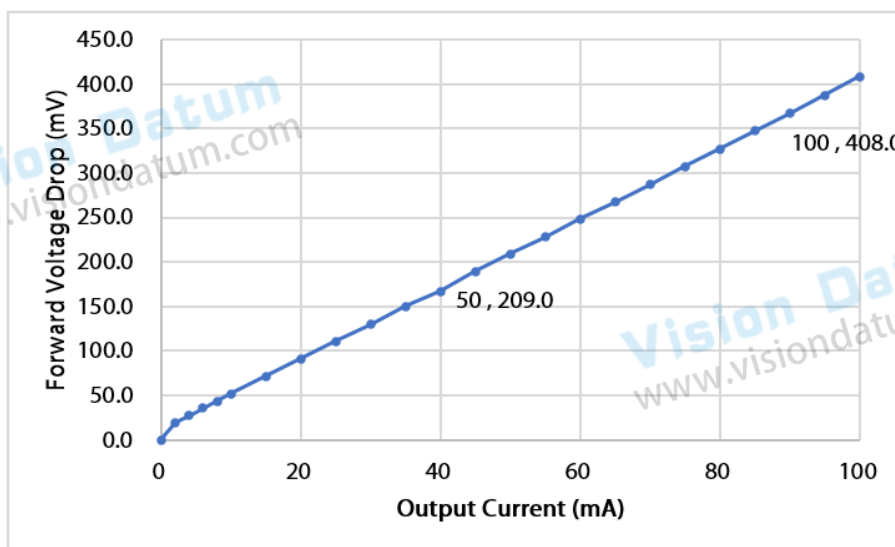

- Values in the line chart are obtained at an environmental temperature of 25° C. Therefore, the actual values may vary among the different models of camera in the different environments.
- The maximum conducting voltage drop is 0.41V (100 mA output current) when the GPIO is defined as the output.

## Configurable GPIO

The signal delay diagram of GPIO output is as follows.

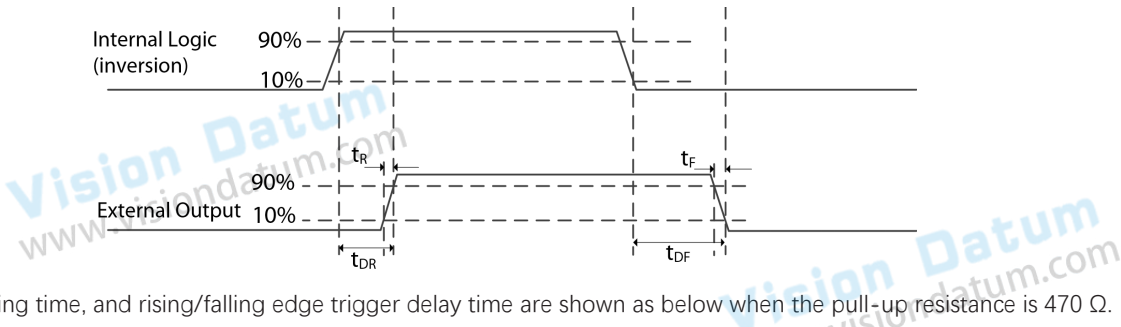

The rising/falling time, and rising/falling edge trigger delay time are shown as below when the pull-up resistance is 470  $\Omega$ .

External Voltage (V)	Rising Time $t_R$ ( $\mu s$ )	Falling Time $t_F$ ( $\mu s$ )	Rising Edge Trigger Delay $t_{DR}(\mu s)$	Falling Edge Trigger Delay $t_{DF}(\mu s)$
Null	-	-	5.43	0.35
5	0.16	0.02	1.80	39
12	0.22	0.04	2.37	71



- The output delay measurement measures the delay value from the FPGA output pins to the GPIO pins, which means the internal logic delay of the FPGA is not included.
- When no external pull-up resistor exists, the shortest output positive pulse is 11  $\mu s$  and the shortest output negative pulse is 1  $\mu s$ .
- The delay time of GPIO interface is less than that of the opto-isolated interface.

## External Wiring

### ■ Wiring of Opto-Isolated Input

#### Application Example of Connect Camera with Sensor: Connect Sensor with NPN Output

Method 1: Add Pull-up Resistor

The opto-isolated input (Line1) and opto-isolated output (Line0) of camera are both available. The diagram of opto-isolated input connects to the sensor with NPN output is as follows.

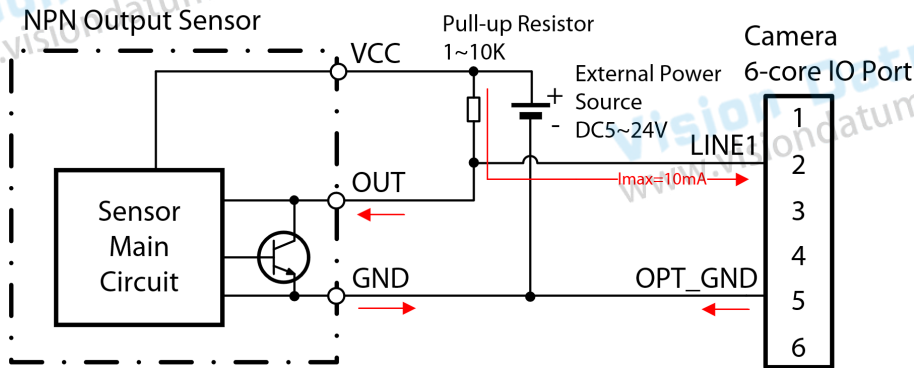

- If the range of pull-up resistance is 1kΩ~10kΩ, the resistance and voltage shall be 1 kΩ at 5 V, 2.4 kΩ at 12V, 4.7 kΩ at 24V.
- The input (Line1) logic state of camera is opposite to the output endpoint state of sensor. When the output state of sensor is "ON", the transistor inside the sensor is turned on. Then, "OUT" and "GND" will be shorted, and the input (Line1) is low-level which corresponds to the logic value "0". When the output state of sensor is "OFF", the transistor is turned off. Then, "OUT" is pulled up to the external power supply by external resistance, and the input (Line1) is high-level which corresponds to the logic value "1".
- The red arrow in the figure indicates the current direction.

Method 2: Without Pull-up Resistor

The opto-isolated input (Line1) of camera is available only. The diagram of opto-isolated input connects to the sensor with NPN output is as follows.

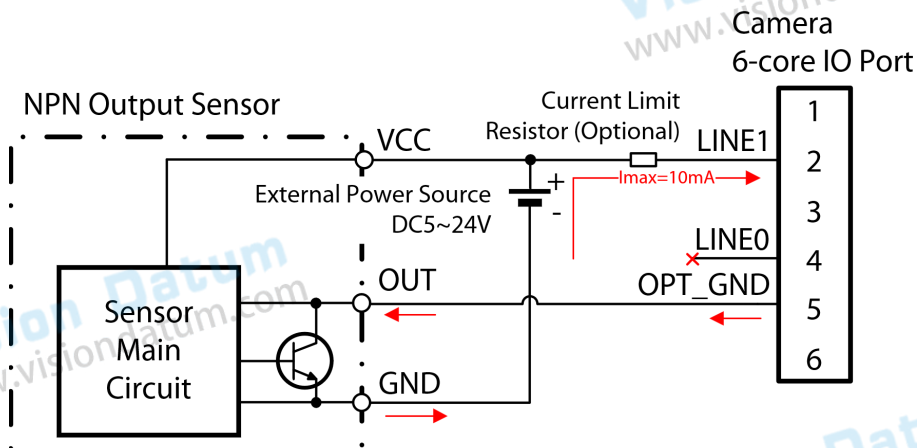

- Generally, the current limiting resistor can be omitted. When the external power supply is 24 V and the voltage is unstable, we recommend you connect a 1kΩ resistor in series on the input (Line1) to avoid overvoltage damage to the camera input circuit.
- The input (Line1) logic state of camera is identical to the output endpoint state of sensor. When the output state of sensor is "ON", the transistor inside the sensor is turned on, and the "OUT" and "GND" are shorted. The current supplied by external power supply flows into the Line1 through the current limiting resistor (optional). After the current passes through the opto-isolated input circuit inside the camera, it flows out from the "OPT\_GND", and it passes through the transistor inside the sensor and flows back to the external power ground (GND).

## External Wiring

### Application Example of Connect Camera with Sensor: Connect sensor with PNP output

The diagram of opto-isolated input connects to the sensor with PNP output is as follows.

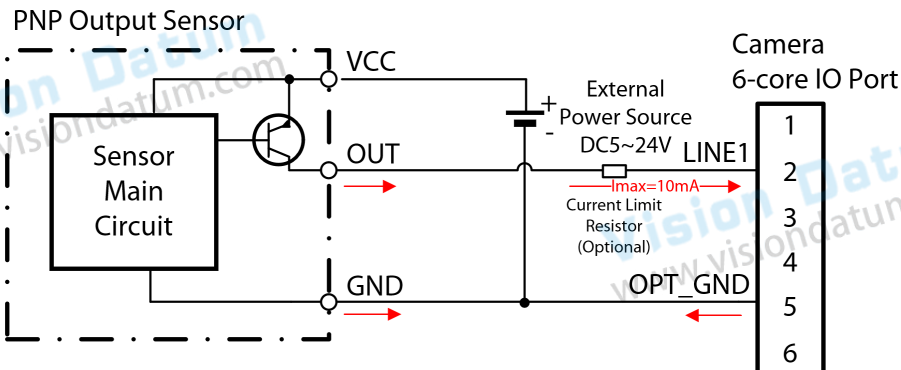

i

- Generally, the current limiting resistor can be omitted. When the external power supply is 24 V and the voltage is unstable, we recommend you connect a 1kΩ resistor in series on the input (Line1) to avoid overvoltage damage to the camera input circuit.
- The input (Line1) logic state of camera is identical to the output endpoint state of sensor. When the output state of sensor is "ON", the transistor inside the sensor is turned on, and the "VCC" and "OUT" are shorted. The current supplied by external power supply flows out from the "OUT" through the transistor inside the sensor, and then flows into the Line1 through the current limiting resistor (optional). After the current passes through the opto-isolated input circuit of camera, it flows out from the "OPT\_GND", and back to the external power ground (GND).

### Application Example of Connect Camera with Sensor: Connect TTL Output

The opto-isolated input (Line1) and opto-isolated output (Line0) of camera are both available. The diagram of opto-isolated input connects to the TTL output is as follows.

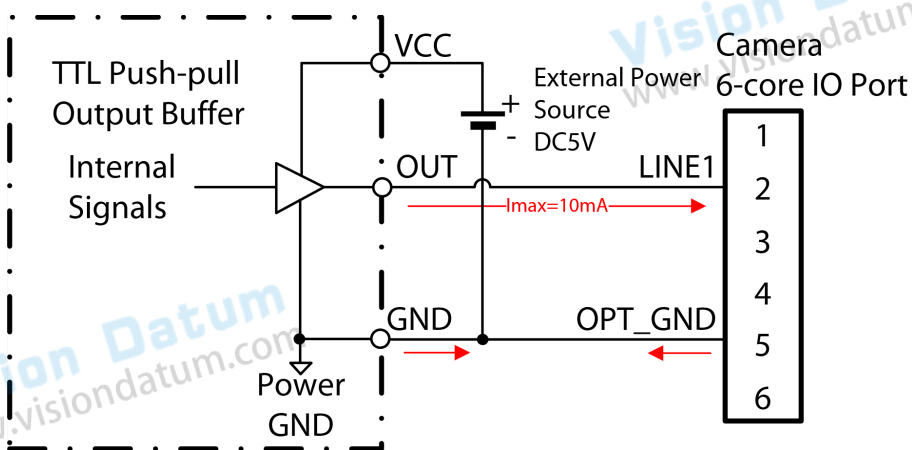

i

The TTL circuit can be the frame grabber or the sensor with complementary push-pull output.

## External Wiring

For the transistor-type PLC output circuit, the port of I/O circuit which outputs or provide current is called Source; the port of I/O circuit which input or flows in current is called Sink. The sink output adopts NPN transistor, and the source output adopts PNP or NPN transistor. The multi-group output of PLC share one common port (COM). The common port of sink output connects to the power ground (0V), and the common port of source output connects to the power supply (VCC).

### Application Example of Connect Camera with PLC: Connect to Sink Output (Common Collector) of PLC

Method 1: Without Pull-up Resistor

The opto-isolated input (Line1) of camera is available only in this method. The diagram of opto-isolated input connects to the sink output of PLC is as follows.

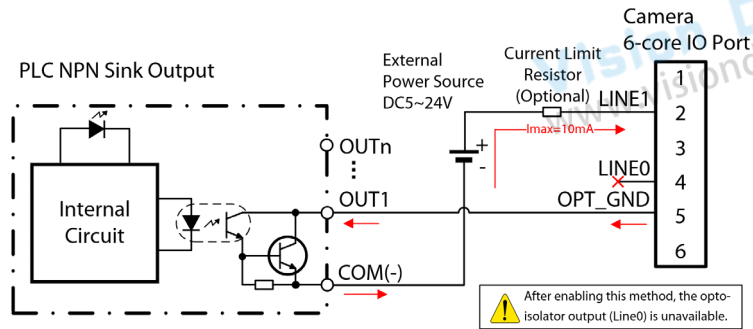

- The output circuit of PLC in the figure refers to the OMRON CP1E-E10. The COM is the common port, and the OUT1~OUTn are the output ports sharing the same common port.
- The opto-isolated output (Line0) of camera is unavailable when you adopt the wiring method in the figure above.
- Generally, the current limiting resistor can be omitted. When the external power supply is 24 V and the voltage is unstable, we recommend you connect a 1kΩ resistor in series on the input (Line1) to avoid overvoltage damage to the camera input circuit.

Method 2: Add Pull-up Resistor

The opto-isolated input (Line1) and opto-isolated output (Line0) of camera are both available. The diagram of opto-isolated input connects to the sink output of PLC is as follows.

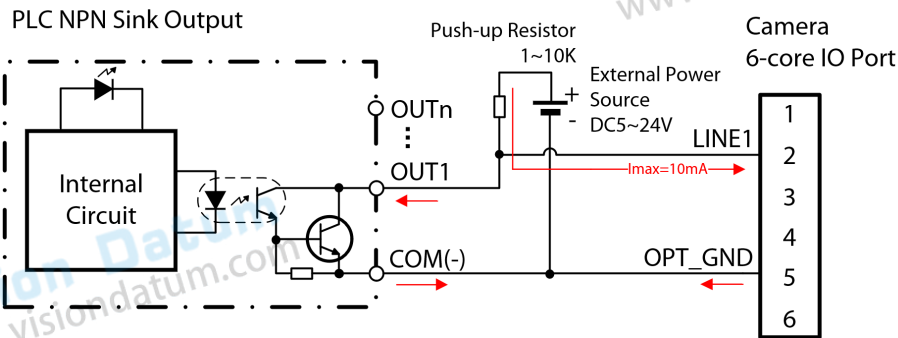

- The output circuit of PLC in the figure refers to the OMRON CP1E-E10. The COM is the common port, and the OUT1~INn are the output ports sharing the same common port.
- If the range of pull-up resistance is 1kΩ~10kΩ, the resistance and voltage shall be 1 kΩ at 5 V, 2.4 kΩ at 12V, 4.7 kΩ at 24V.
- The input logic state of camera is opposite to the output port state of sensor. The detailed descriptions, please refer to the "Application Example of Connect Camera with Sensor".

## External Wiring

### Application Example of Connect Camera with PLC: Connect to Source Output (Common Emitter) of PLC

The diagram of opto-isolated input connects to the source output of PLC is as follows.

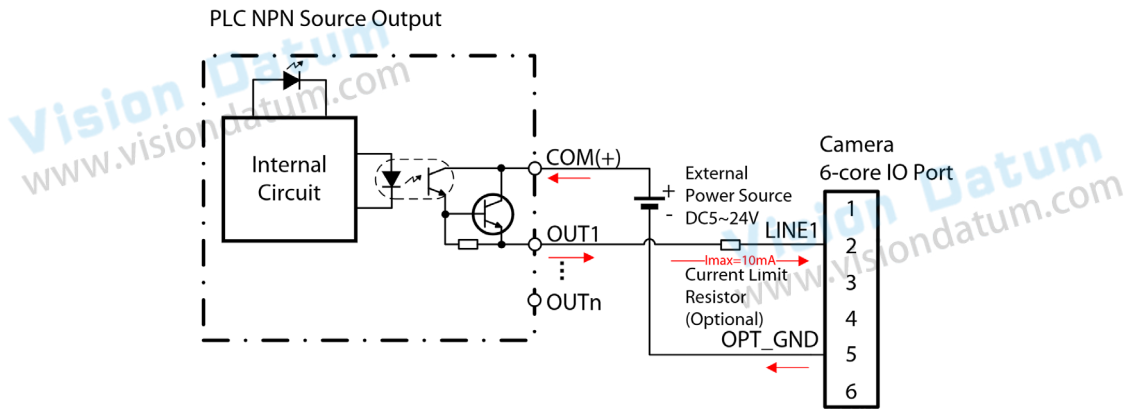

- The output circuit of PLC in the figure refers to the OMRON CP1E-E10. The COM is the common port, and the OUT1~OUTn are the input ports sharing the same common port.
- Generally, the current limiting resistor can be omitted. When the external power supply is 24 V and the voltage is unstable, we recommend you connect a 1kΩ resistor in series on the input (Line1) to avoid overvoltage damage to the camera input circuit.
- The input logic state of camera is identical to the output port state of sensor. The detailed descriptions, please refer to the section of Connect To PNP Output of Sensor.

## External Wiring

### ■ Wiring of Opto-Isolated Output

#### Opto-isolator as NPN Output Connects to Indicator and Buzzer

The diagram of opto-isolator as NPN output connects indicator is as follows.

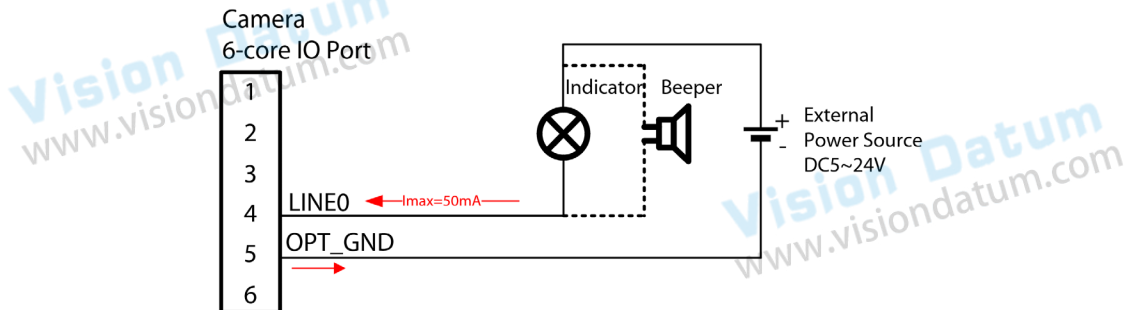

The red arrow in the figure indicates the current direction when the output of opto-isolator is in the conductive state (Logic 1).

#### Opto-isolator as NPN Output Connects to PLC Input

The diagram of the opto-isolator as NPN output connects to PLC input is as follows.

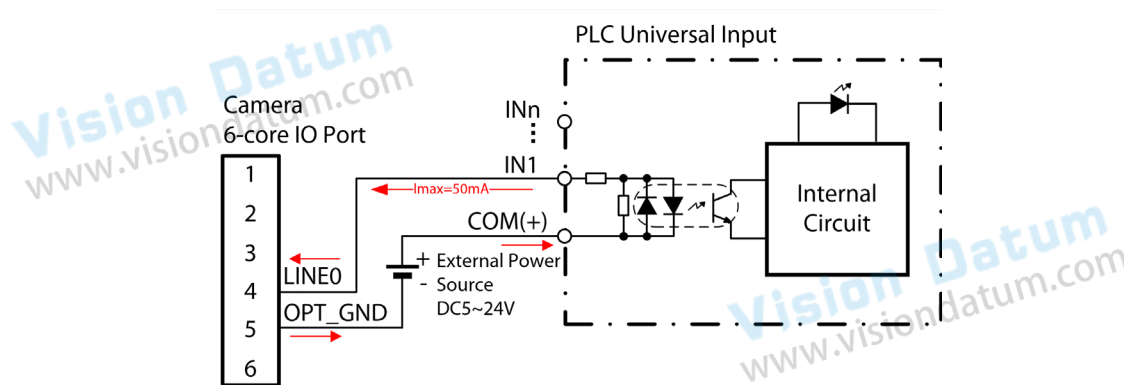

The input circuit of PLC in the figure refers to the OMRON CP1E-E10. The COM is the common port, and the IN1~INn are the input ports sharing the same common port.

#### Opto-isolator as PNP Output Connects to PLC Input

The diagram of the opto-isolator as PNP output connects to PLC input is as follows.

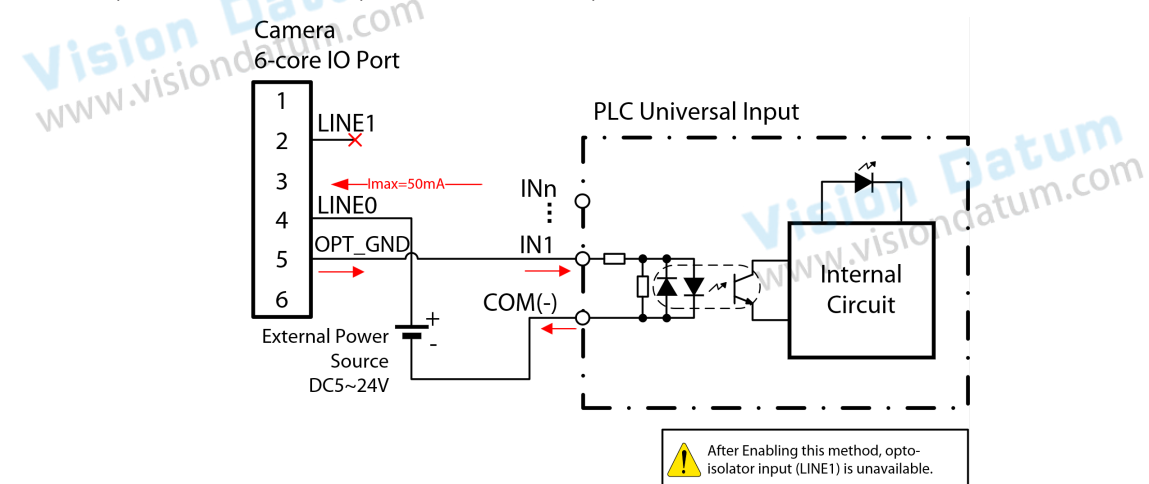

⚠ After Enabling this method, opto-isolator input (LINE1) is unavailable.



- The input circuit of PLC in the figure refers to the OMRON CP1E-E10. The COM is the common port, and the IN1~INn are the input ports sharing the same common port.
- The opto-isolated input (Line1) of camera is unavailable when you adopt the wiring method in the figure above.

## External Wiring

### Opto-isolator as NPN Output Connects Light Controller

The diagram of the opto-isolator as NPN output connects to light controller is as follows.

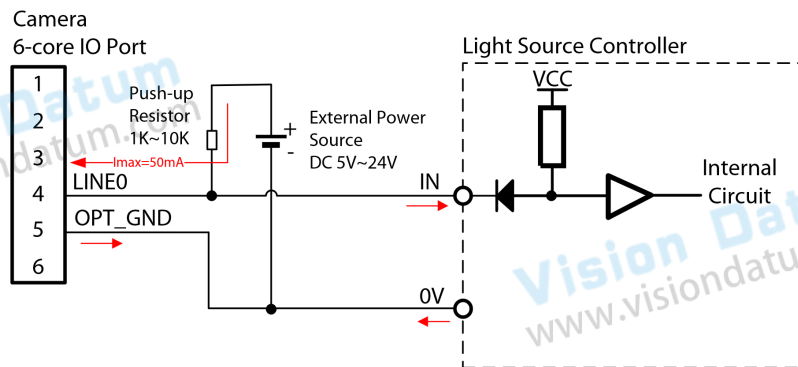

The resistance value range of the pull-up resistor is 1kΩ~10 kΩ. It is 1kΩ at 3.3V or 5V, 2.4kΩ at 12V, and 4.7kΩ at 24V. If the light controller has the built-in pull-up resistor, the external resistor is not needed.

## External Wiring

### Configurable GPIO Wiring

#### Application Example of GPIO As Input

The diagram of GPIO as input connects to the mechanical switch is as follows.

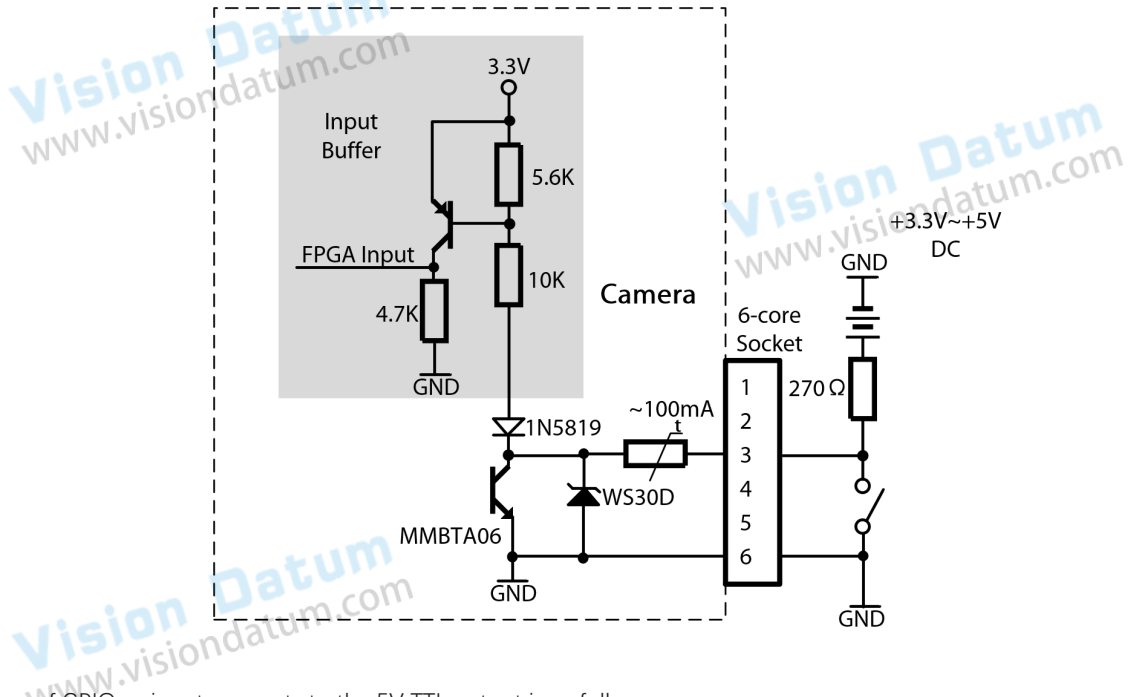

The diagram of GPIO as input connects to the 5V TTL output is as follows.

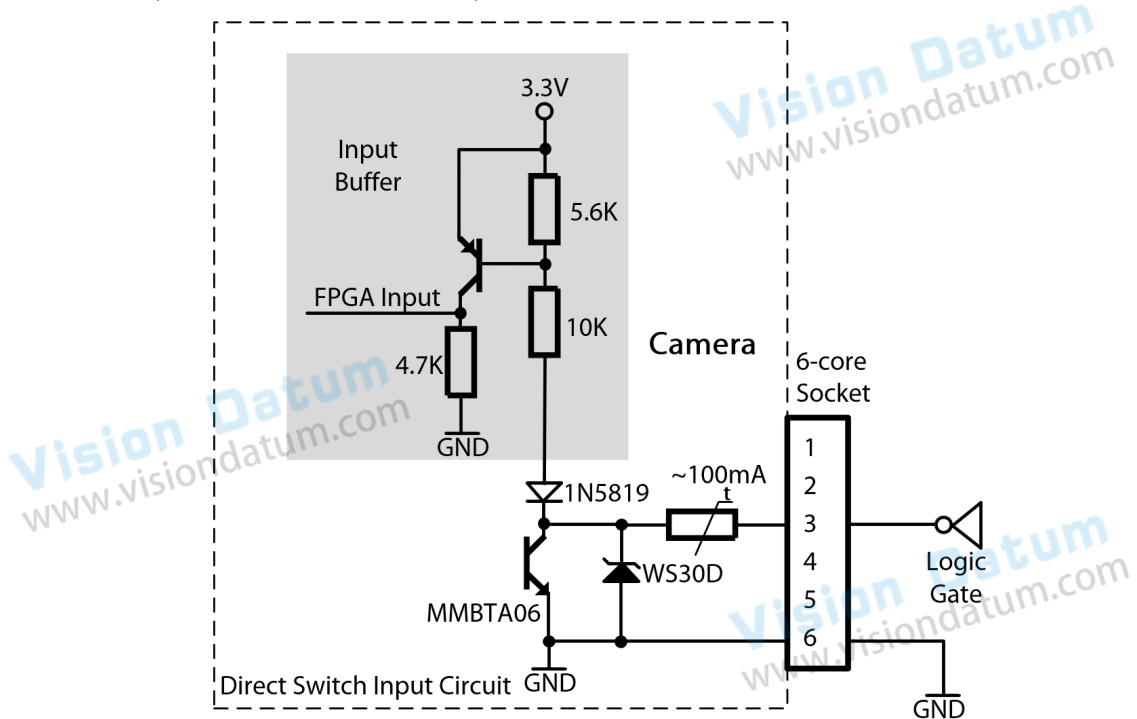

## External Wiring

### Application of GPIO As Output

GPIO as output connects to the PLC input interface is as follows.

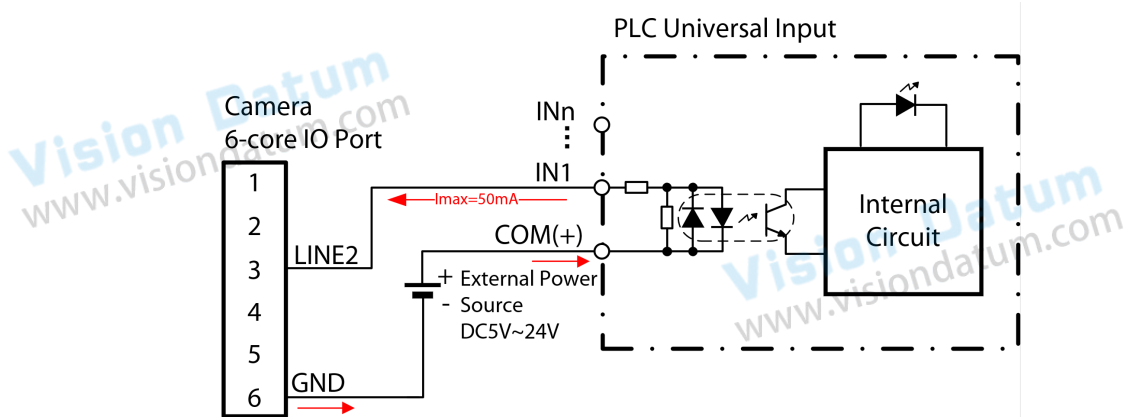

- |   |  |
|---|--|
|  | <ul style="list-style-type: none"> <li>● Do not apply the voltage or connect load on the output terminals which exceeds the allowed maximum value.</li> <li>● Do not replace the fuse by yourself. If the fuse blows due to the overcurrent, such as short circuit, please contact our after-sales to provide the maintenance service.</li> <li>● Before you connect the external circuit, please define the GPIO as the proper direction, such as input or output. Do not change the direction of GPIO when the camera is running. The wrong direction may cause damages on the GPIO interface.</li> <li>● Please do not use the GPIO interface in the environment with serious electrical interference. Because the GPIO interface is a non-isolated interface, which means it has no sufficient anti-interference performance. We recommend you use the opto-isolated input or output interface, such as Line1, Line0.</li> </ul> |
|---|--|

## CHAPTER 6 Image Processing

### Pixel Bit

The pixel bits of different pixel formats may vary. Take the pixel format Mono8 as an example, the pixel bit of it is as follows.

PixelFormat	Mono8
PixelSize	Bpp8

The pixel bits of different pixel formats of GigE area scan camera are described in the table below.

PixelFormat	PixelSize (Bits/Pixel)
Mono 8、Bayer 8	8
Mono 10 Packed、Mono 12 packed、Bayer 10 Packed、Bayer 12 packed	12
Bayer 10、Bayer 12、YUV422_8_UYVY、YUV422_8	16
RGB8、BGR8	24

### Pixel Format

The GigE area scan camera supports many pixel formats. Different models and configurations have different pixel formats. For more details, please refer to the technical specifications. The pixel format selection is shown in the figure below.

ReverseX	Mono8
PixelFormat	BayerRG8
HighSensitivity	BayerRG10
BayerDrawlineEnable	BayerRG12
PixelSize	BayerRG10Packed
PixelColorFilter	BayerRG12Packed
PixelDynamicRangeMin	RGB8Packed
PixelDynamicRangeMax	YUV422_8_UYVY
TestImageSelector	BGR8
SensorColorType	
PixelSizeInput	

The pixel format patterns of color camera are as follows.



Bayer GR pixel pattern

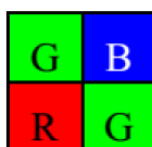

Bayer GB pixel pattern



Bayer BG pixel pattern

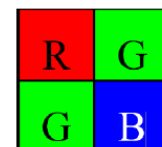

Bayer RG pixel pattern

## Resolution and ROI

The image will be produced at the maximum resolution under the default configuration of the camera. The maximum resolution of camera can be checked in the parameters of WidthMax and HeightMax under the ImageFormatControl. See the following figure:

WidthMax	1,440
HeightMax	1,080

- WidthMax means that the maximum resolution of camera at the width direction.
- HeightMax means that the maximum resolution of camera at the height direction.

ROI (Region of Interest) allows users to specify a certain part of the image by adding the recognition frame box and to output the pixel information of the specified recognition area. See the following figure:

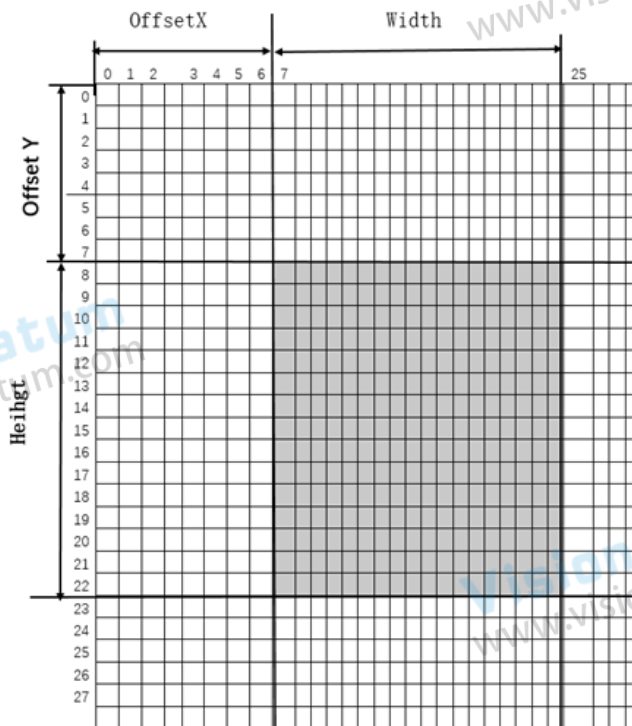

- The location and size of the ROI can be defined by configuring the parameters including OffsetX , OffsetYWidth, and Height.

User can configure the following four parameters under the ImageFormatControl to draw a ROI.

Width	300
Height	200
OffsetX	100
OffsetY	100

Parameter	Description
Width	The resolution of the ROI at the X direction.
Height	The resolution of the ROI at the Y direction.
OffsetX	The X coordinate of the starting point in the upper left corner of the ROI.
OffsetY	The Y coordinate of the starting point in the upper left corner of the ROI.

- The sum of Width and OffsetX shall not greater than the WidthMax.
- The sum of Height and Offset Y shall not greater than the HeightMax.
- The stepping of parameters mentioned above may vary depending on the device model. Please refer to the actual parameters on your software client.

## Binning

The binning function can merge multiple pixels into one pixel, which means it can lower the resolution and improve the image brightness or signal-to-noise ratio while the scene of image remains unchanged.

### ■ Mono Camera

#### Set Binning to 2 in Horizontal

For the mono cameras, when user set the Binning to '2' in horizontal direction, the 'p1' and 'p2' are merged to generate the pixel 'P1'; the 'p3' and 'p4' are merged to generate the pixel 'P2', as shown in the figure below.



#### Set Binning to 2 in Vertical

For the mono cameras, when user set the Binning to '2' in vertical direction, the 'p1' and 'p3' are merged to generate the pixel 'P1'; the 'p2' and 'p4' are merged to generate the pixel 'P2', as shown in the figure below.



### ■ Color Camera

#### Set Binning to 2 in Horizontal

For the color cameras, when user set the Binning to '2' in horizontal direction, the 'R1' and 'R2' are merged to generate the pixel 'R'; the 'Gr1' and 'Gr2' are merged to generate the pixel 'Gr'; the 'Gb1' and 'Gb2' are merged to generate the pixel 'Gb'; the 'B1' and 'B2' are merged to generate the pixel 'B', as shown in the figure below.

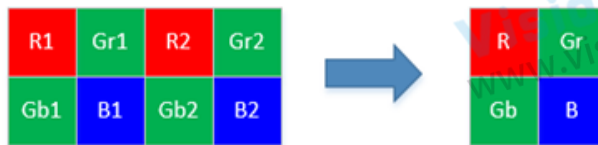

#### Set Binning to 2 in Vertical

For the color cameras, when user set the Binning to '2' in vertical direction, the 'R1' and 'R2' are merged to generate the pixel 'R'; the 'Gr1' and 'Gr2' are merged to generate the pixel 'Gr'; the 'Gb1' and 'Gb2' are merged to generate the pixel 'Gb'; the 'B1' and 'B2' are merged to generate the pixel 'B', as shown in the figure below.



#### Set Binning to 2 in Horizontal and Vertical

For color cameras, when user set the Binning to '2' in horizontal and vertical directions, the 'R1' 'R2' 'R3' and 'R4' are merged to generate the pixel 'R', and so on to generate other pixels.



## Binning

### ■ Binning Mode and Mode Combination

There are four modes of Binning, which are described in the table below.

Binning Mode	Description
Avg	Average
Sum	Summation
AvgXSumY	To average the pixels at the horizontal direction; to sum the pixels at the vertical direction.
AvgYSumX	To sum the pixels at the horizontal direction; to average the pixels at the vertical direction.

The parameter of BinningMode is shown in the figure below.

Binning	Off
<b>BinningMode</b>	Avg
PixelScalingEnable	Sum
PixelScalingWidth	AvgXSumY
PixelScalingHeight	AvgYSumX
SensorWidth	

There are a variety of combinations in horizontal and vertical directions to choose from the Binning.

<b>Binning</b>	Off
BinningMode	OneByTwo
PixelScalingEnable	TwoByOne
PixelScalingWidth	TwoByTwo
PixelScalingHeight	TwoByTwo
SensorWidth	OneByFour
SensorHeight	FourByOne
WidthMax	TwoByFour
HeightMax	FourByTwo
Width	ThreeByThree
Height	FourByFour
OffsetX	SixBySix
OffsetY	OneBySix
ReverseX	OneBySix
ReverseY	SixByOne
PixelFormat	



some combinations shown in the figure above may not be supported in some device models. The actual conditions shall prevail.

## Scaling

The scaling function combines the adjacent pixels by algorithm while the FoV of image is unchanged, effectively reducing the image resolution and increasing the frame rate. User can set the scaling in the ImageFormatControl.

Procedure:

Step 1 Set the PixelScalingEnable to On to enable scaling function.

Step 2 Set the target resolution after image reduction in the PixelScalingWidth and PixelScalingHeight.

PixelScalingEnable	Off
PixelScalingWidth	1,624
PixelScalingHeight	1,240



The scaling function is available in some models only, so the actual condition shall prevail.

## Mirroring

The mirroring modes include the X-axis and Y-axis, and user can set the mirroring mode in the ReverseX and ReverseY under the ImageFormatControl.

ReverseX	False
ReverseY	False

Parameter	Description
ReverseX	To mirror the image in X-axis (horizontal).
ReverseY	To mirror the image in Y-axis (vertical).

The scenes before and after performing the mirroring function is unchanged in the ROI mode. The actual condition shall prevail.

## Test Image

User can enable test image function, and select image pattern to troubleshoot abnormalities. The test image function is disabled by default. User can select different test image in the TestImageSelector under the ImageFormatControl. See the following figure:

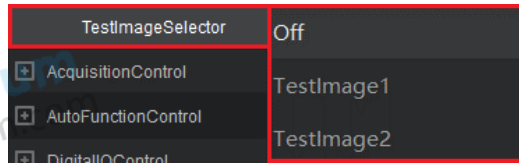

The test images displayed in the below may vary depending on the device model, please refer to the actual condition.

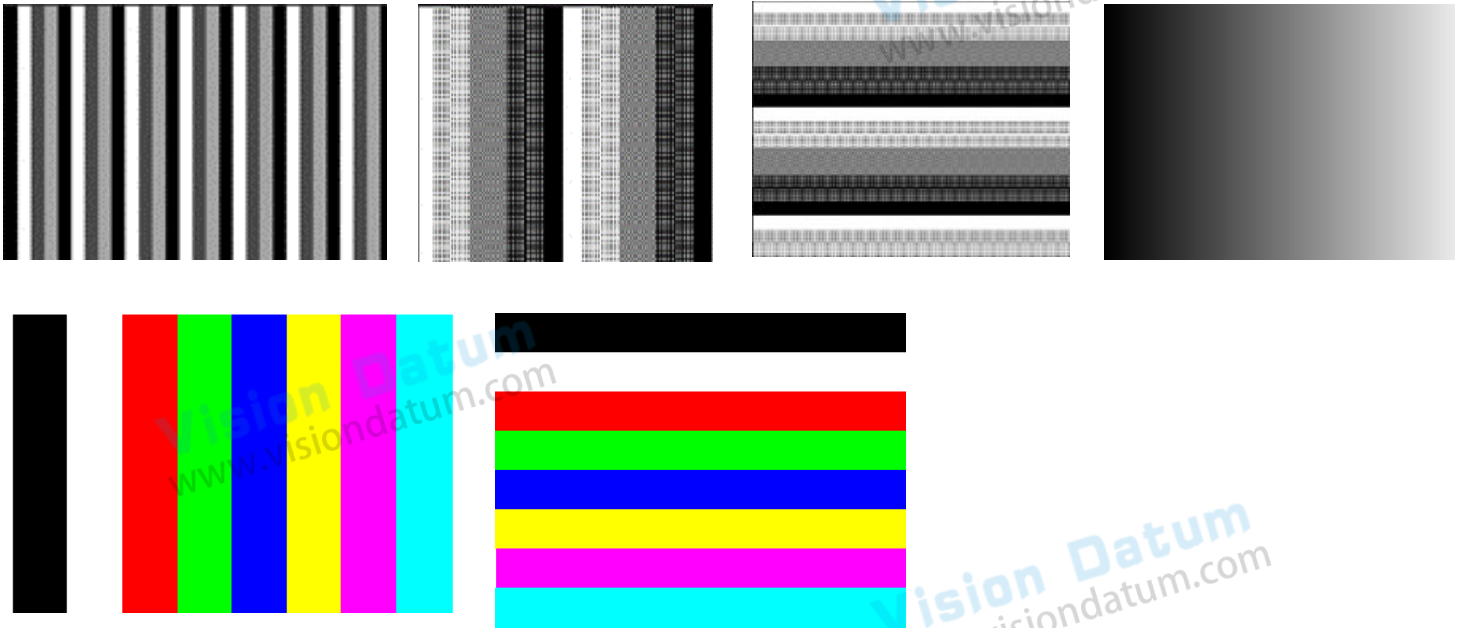

## Gain

The gain function includes analog gain and digital gain. The analog gain can amplify the analog signals outputted by sensor, and the digital gain can amplify the signals after converting analog signals to digital signals. The greater the gain value, the higher the brightness of image, and the image noise will be increased, which affects the image quality. If you need to increase the image brightness, we recommend you increase the exposure time of camera first. If the increase of exposure time does not meet your demand, you can increase the gain value. The following diagrams display the image effect when the gain value is 1 and 2.

### ■ Total Gain

The parameter GainRaw is the total gain of camera, which includes analog gain and digital gain. For example, when you set the GainRaw as the '6.4', the total gain is 6.4 times, of which the analog gain is 3.2 times and the digital gain is 2 times. After setting the GainRaw, camera automatically matches the closest analog gain, ensuring that the camera uses the analog gain first.

### ■ Auto Gain

The gain modes include Off , Once and Continuous. The descriptions of gain modes are shown in the table below.

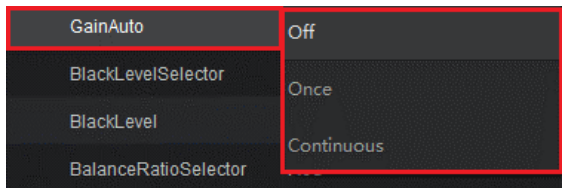

Parameter	Parameter Value	Principle
AnalogControl > GainAuto	Off	Adjust the gain based on the set value of GainRaw.
	Once	Run the auto gain once for a period and then stops according to the environment.
	Continuous	Automatically and continuously adjust the gain according to the environment.

### ■ Digital Gain

The DigitalShift is the digital gain, which is disabled by default. The parameter range is 0~4. For example, if you set the value as X, the digital gain will be 2X. The larger the value, the brighter the image and the more noise. User can configure the value in the parameter of DigitalShift under the ISPControl.

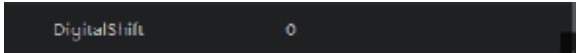

### ■ Brightness

Camera supports another way to adjust the digital gain, namely Brightness . The parameter range is 0~100, and the default value of 50 means one times gain. User can enter the non-integral number to adjust the brightness of image in Brightness under the ISPControl.



## Black Level

Black level helps you adjust the gray value offset of the output data. The gray value offset determines the average gray value when the sensor is not sensitive. Different ADC bit depth modes corresponds to different black level parameter range of the camera. The actual condition shall prevail. If you need to configure the black level manually, the procedures are as follows.

Procedure:

Step 1 Set the BlackLevelAuto under the AnalogControl to Off.

Step 2 Enter the black level value in the BlackLevel, which is for eliminating the influence of sensor dark current.

The relevant parameters of black level are as shown in the figure below.

BlackLevelAuto	Off
BlackLevelSelector	All
BlackLevel	50

The options of black level include Off , Once and Continuous, the details are described in the table below.

Parameter	Parameter Value	Principle
AnalogControl > BlackLevelAuto	Off	Adjust the black level based on the set value of BlackLevel.
	Once	Run the auto black Level once for a period and then stops according to the environment.
	Continuous	Automatically adjust the black level according to the environment.

**i**

- The default values of black level may vary depending on the device models, the actual condition shall prevail.
- The black level will change with the temperature rising; therefore, we recommend you obtain the black level value when the temperature is constant.

## Light Source Preset

The light sources of camera with different color temperatures are preset, and they are related to the functions of white balance, gamma correction, CCM, etc. User can set the LightSourcePreset under the AnalogControl.

LightSourcePreset	Off
BalanceWhiteAuto	Preset6500K
BalanceRatioSelector	Preset4150K
BalanceRatio	Preset4000K
Gamma	Preset3000K
<input checked="" type="checkbox"/> TransportLayerControl	Preset2700K
PayloadSize	Preset2700K

**i**

The light source preset is available in some models only. The actual condition shall prevail.

## White Balance

The images obtained by color camera in different light source environments may have color cast. For example, the images are too blue under fluorescent lamp, and too yellow under incandescent lamp. The reason is that different light sources have different color temperatures. To ensure the white area of image can remain white at different color temperature, the color camera supports the white balance function. This function corrects the color cast by adjusting the intensity of red R, green G and blue B. User can configure these three parameters in the WhiteBalance under the AnalogControl.

Parameter	Parameter Value	Principle
AnalogControl > BalanceWhiteAuto	Off	User can manually debug the values of Red, Green, Blue in the BalanceRatioSelector and BalanceRatio.
	Once	Runs white balance adjustment automatically for a period and then stops based on the current situation.
	Continuous	Automatically adjust the white balance according to the environment.

When the color effect of the image is different from the actual situation, you can enable the white balance to calibrate it. The detailed procedures are as follows.

Procedure:

Step 1 Prepare one white paper and put it within the camera's FoV, so that the white paper fills the whole field of view.

Step 2 Set the exposure gain preferentially. The recommend range of image brightness is 80~160.

Step 3 Set the BalanceWhiteAuto to the Continuous or Once to perform the auto white balance correction, as shown in the figure below.

After finishing the procedures above, if the corrected effect is still different from the actual condition, you can perform white balance correction manually. The detailed procedures are as follows.

Step 4 Set BalanceWhiteAuto to Off, that is, manual mode.

Step 5 Find the value of R, G, and B components, which are 1.0 in BalanceRatio, and observe the values of R/G/B and then adjust the values of other two components to make channels of R, G, and B of the image consistent. At this time, the white balance of image should be consistent with the actual condition.



- After the white balance correction is completed, we recommend you save the user-defined parameters to avoid the parameters reset after restarting the camera.
- If the light source and color temperature in the environment are changed, you need to readjust the white balance.

## Gamma Correction

The most output of sensor is liner with the light intensity irradiating on the photosensitive surface of chip, however, the gamma correction is a non-linear mapping, which makes the original image outputted from sensor more in line with the perception of the human eye after gamma correction. The mapping relationship of gamma correction can be expressed by the formula in the below.

$$Y_{\text{corrected}} = \left( \frac{Y_{\text{uncorrected}}}{Y_{\text{max}}} \right)^{\gamma} \times Y_{\text{max}}$$

The parameter of Gamma is under the AnalogControl. The value range is 0~3.99998, as shown in the figure below.

Gamma	0.45455
-------	---------

When the value of gamma is '1', the image brightness remains unchanged; when the value of gamma is between '0' and '1', the image brightness is increased; when the value of gamma is greater than '1', the image brightness is lowered, as shown in the chart below.

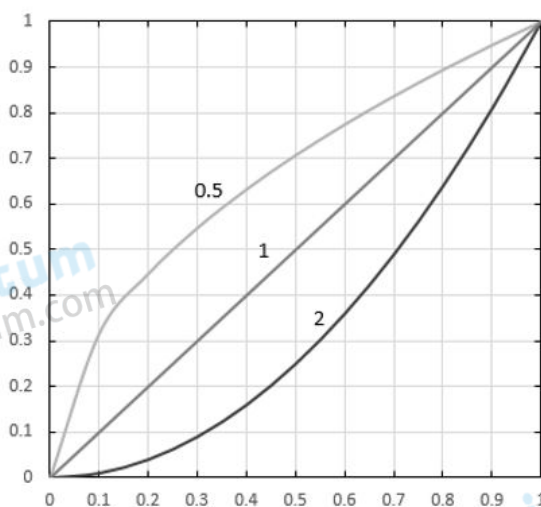

## Sharpness

The sharpness function can adjust the sharpening degrees of edges of contents in image to improve the image clarity. The detailed procedures of setting sharpness are as follows.

Procedure:

Step 1 Enable or disable the sharpness function in the SharpnessEnabled under the ISPControl.

Step 2 After enabling the sharpness function, you can set the values in the Sharpness. The value range is 0~100, as shown in the figure below.

SharpnessEnabled	On
Sharpness	50.00

## Denoise

Some devices support denoise function, which can reduce the image noises to achieve the edge-preserving smoothing and improve signal-to-noise ratio and image quality. The detailed procedures of setting denoise are as follows.

Procedure:

Step 1 Enable or disable the denoise function in the DenoisingEnabled or DenoisingYuvEnabled under the ISPControl.

Step 2 After enabling the denoise function, you can set the values in the Denoising or DenoisingYuv. The value range is 0~100, as shown in the figure below.

DenoisingEnabled	On
Denoising	50
DenoisingYuvEnabled	On
DenoisingYuv	50

## Pseudocolor Elimination

The pseudocolor elimination can solve the “edge false colors” problem caused by lens refraction or other lights, and solve the color cast problem caused by the algorithm, such as interpolation, etc. Therefore, this function can effectively reduce the color error in the image to improve the color fidelity and image definition. User can set the value in the PseudocolorElimination under the ISPControl.



User can set the value of pseudocolor elimination in the PseudocolorElimination. The diagrams of pseudocolor elimination effects when value is 10 and 0 are as follows.

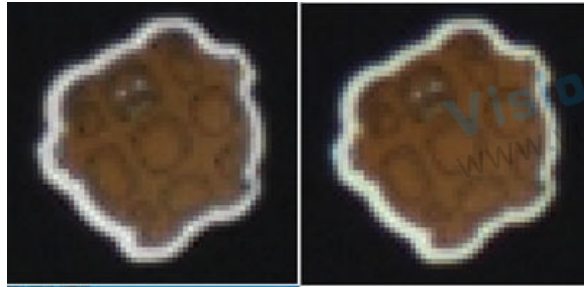

- The pseudocolor elimination is available in some models only. The actual device shall prevail.
- The pseudocolor elimination is only available in RGB, BGR, Bayer and YUV pixel formats of color camera.

## Hue and Saturation

User can adjust the hue and saturation to the overall color of image produced by color camera in the Hue and Saturation under the ISPControl, as shown in the figure below.



The diagram of effect comparison of different hues is as follows.

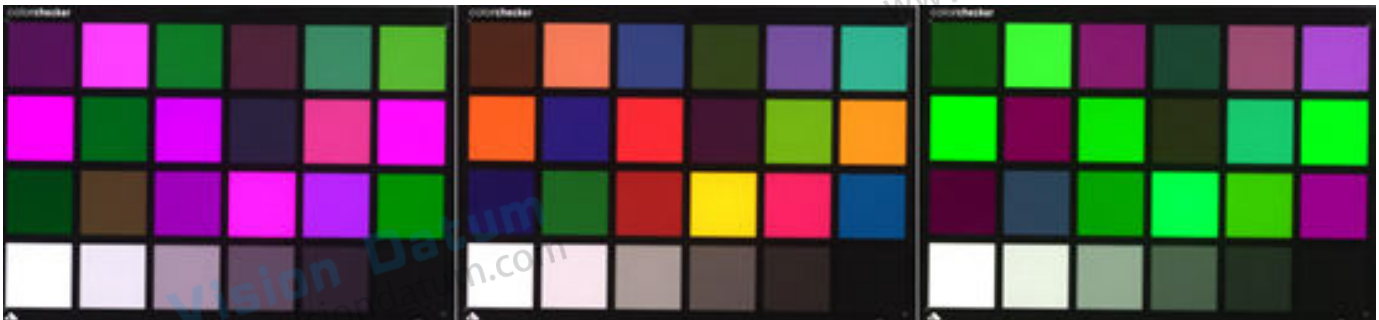

The diagram of effect comparison of different saturations is as follows.



- The hue and saturation are available in some models only. The actual device shall prevail.

## Contrast

The Contrast is supported by some camera models. This function can adjust the difference level between the light and dark areas in the image. The greater the contrast, the more pronounced the difference. The Contrast is in the ISPControl, as shown in the figure below.

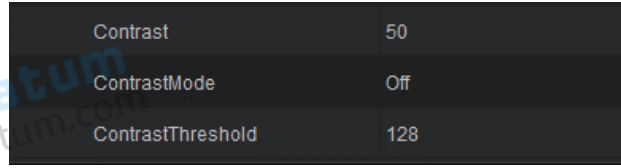

User can adjust the difference level of contrast in Contrast.

User can set the contrast mode in ContrastMode, the contrast modes are described in the following table.

Parameter	Parameter Value	Principle
ISPControl > ContrastMode	Off	It will adjust the contrast based on the set value of Contrast.
	Once	Automatically adjust the contrast once for a period and then stops according to the environment.
	Continuous	Automatically and continuously adjust the contrast according to the environment.

User can set the transition points of stretching and compression for adjusting the image contrast in ContrastThreshold.

- The contrast function is available in some models. The actual device shall prevail.
- The auto-contrast function is available for mono model devices.
- The name of parameters in different device models may vary. For example, the Contrast may be called ContrastValue, and ContrastThreshold may be called ContrastPivotValue. Please refer to the actual condition.
- The ContrastType is available in some models. This parameter can provide the brightness mapping relationships functions for contrast, including "linear" and "S-curve".

## FFC

User can use the FFCEnable (Flat Field Correction) to eliminate the problem of uneven image brightness caused by uneven illumination, sensor fixed noise and uneven response. This function is available in some device models only. User can find the FFC function on the CamTools. Open the CamTools, and click the tab of FFC. User can follow the tooltips to complete the corresponding operations.

After performing the FFC, the FFCEnable under the ISPControl is available which is to enable the correction parameters of FFC, as shown in the figure below.

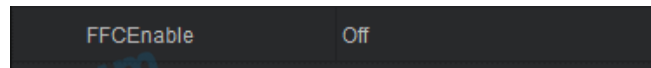

The images before and after FFC are shown in the below.

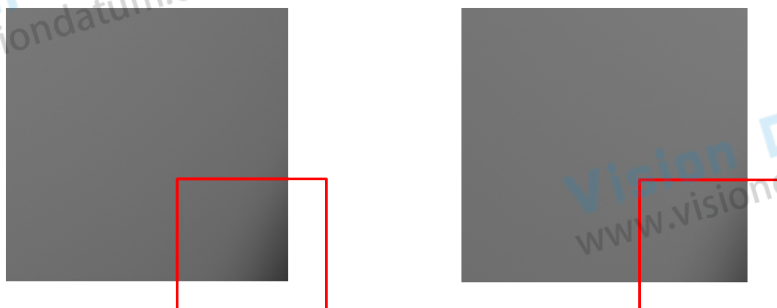

- The FFCEnable is available in some models. The actual condition shall prevail.
- The FFCEnable can only be performed at the full resolution. If the camera is not at the full resolution, you should restore it before making corrections.

## Six-Axis Adjustment

The ColorAdjustmentSelector under the ISPControl can adjust the hue and saturation of different color regions of image, which facilitates users to quickly adjust the image color based on the actual demands. HSV diagram is as follows.

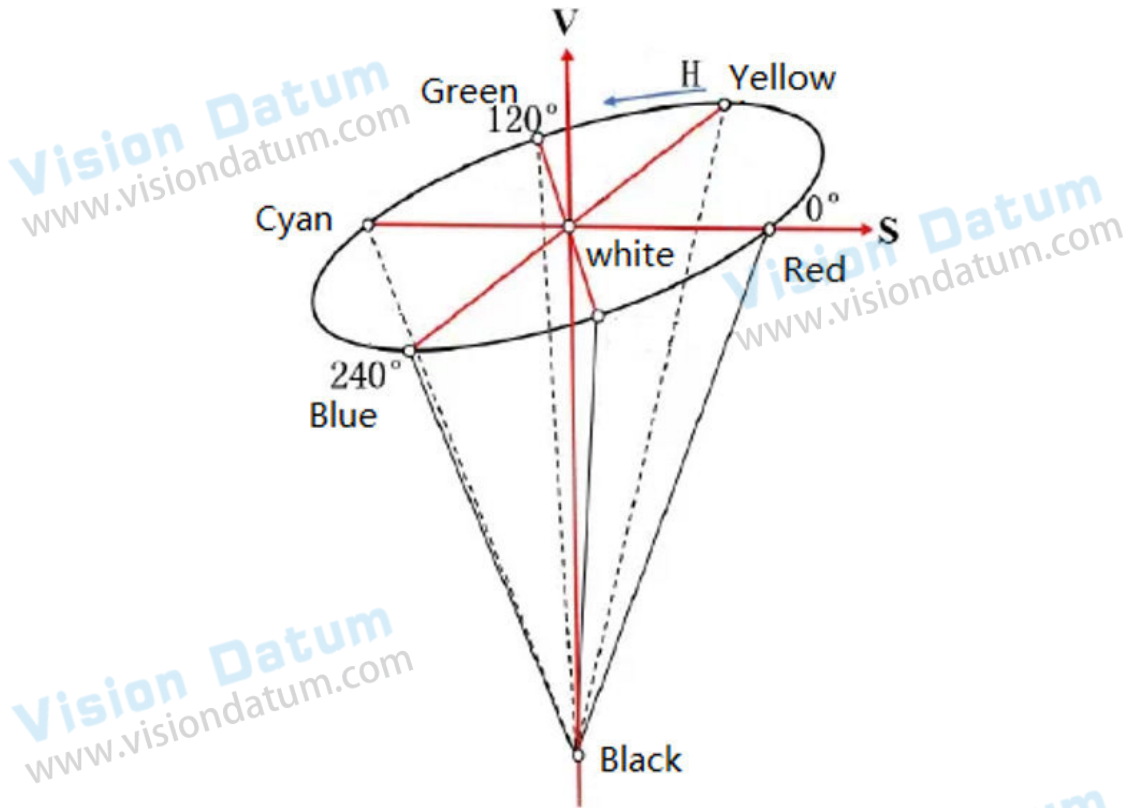

Procedure:

Step 1 Select the color region to be adjusted in the ColorAdjustmentSelector based on the actual demands.

ColorAdjustmentSelector	Red
ColorAdjustmentHue	Yellow
ColorAdjustmentSatura...	Green
ColorAdjustmentConfig...	Cyan
FFCEnable	Blue
SequencerFPGAControl	Blue
SequencerFPGAMode	Magenta

Step 2 Modify the values of selected color region in the ColorAdjustmentHue and ColorAdjustmentSaturation.

ColorAdjustmentHue	0
ColorAdjustmentSaturation	200

Step 3 Reset all parameters of 6-axis adjustment to the default, you can click the ColorAdjustmentConfigurationReset, as shown in the figure below.

ColorAdjustmentConfigurationReset	ColorAdjustmentConfigurationReset
-----------------------------------	-----------------------------------



- The 6-axis adjustment is available in some models only. The actual condition shall prevail.
- It is only available in RGB, BGR, Bayer and YUV pixel formats of color camera.

## HDR

User can use this function to improve the clear imaging capabilities of camera in scenes with significant contrast between light and dark. Click ISPControl > HDRControl > ClearHDR.



**i** The HDR function is available in some models only. The actual condition shall prevail.

## LUT

The LUT is a grayscale mapping table. User can set the user-defined grayscale mapping relations flexibly, such as stretching and compressing the brightness range of ROI. The relevant parameters of LUT are shown in the figure below.

The detailed procedures of setting LUT are as follows.

Procedure:

Step 1 Enable or disable the LUT in the LUTEnable under the LUTControl.

Step 2 Set the original grayscale values to be mapped in the LUTIndex.

Step 3 Set the target grayscale value to be mapped in the LUTValue, and the value ranges of LUTValue and LUTIndex are the same.

LUTSelector	Luminance
LUTEnable	True
LUTIndex	0
LUTValue	0

**i**

- The LUT function is available in some models only. The actual condition shall prevail.
- Gamma correction and LUT can both adjust the gray mapping relations; therefore, these two functions cannot be enabled at the same time.
- The value range of LUTIndex depends on the ADC bit depth of sensor. 10bit: 0~1023; 12bit: 0~4095.

## Color Conversion Control

### ■ RGB to YUV

Before the image is outputted in the YUV format, the color components of RGB will be multiplied with the conversion matrix to provide the proper color space which satisfies the user's expectations. User can set the relevant parameters in the ColorTransformationControl, as shown in the figure below.

The detailed procedures are as follows.

Procedure:

Step 1 Set the ColorTransformationSelector to RGBtoYUV.

Step 2 Set the ColorTransformationEnable to True to enable this function.

Step 3 Configure the parameters of conversion matrix in the ColorTransformationValueSelector and ColorTransformationValue.

ColorTransformationSelector	RGBtoYUV
ColorTransformationEnable	True
ColorTransformationValueSelector	Gain00
ColorTransformationValue	1.00000



- The RGBtoYUV is available in some models only, so the actual condition shall prevail.
- The descriptions about the options of ColorTransformationValueSelector are as follows.  
Gain00 , Gain01, Gain02 and offset0 refer to the Y component.  
Gain10 , Gain11, Gain12 and offset1 refer to the U component of green pixels.  
Gain20 , Gain21, Gain22 and offset2 refer to the V component of blue pixels.

### ■ CCM

After performing the white balance on the image, it may have different degrees of color deviation. You can enable the CCM function to correct the color to the standard values. It multiplies each RGB component with the correction matrix to correct the color.

$$\begin{bmatrix} R_{out} \\ G_{out} \\ B_{out} \end{bmatrix} = \begin{bmatrix} Gain_{00} & Gain_{01} & Gain_{02} \\ Gain_{10} & Gain_{11} & Gain_{12} \\ Gain_{20} & Gain_{21} & Gain_{22} \end{bmatrix} * \begin{bmatrix} R_{in} \\ G_{in} \\ B_{in} \end{bmatrix} + \begin{bmatrix} offset0 \\ offset1 \\ offset2 \end{bmatrix}$$

You can configure the relevant parameters in the ColorTransformationControl, as shown in the figure below.

Procedure:

Step 1 Set the ColorTransformationSelector to RGBtoRGB.

Step 2 Set the ColorTransformationEnable to True to enable this function.

Step 3 Configure the parameters of correction formula in the ColorTransformationValueSelector and ColorTransformationValue.

ColorTransformationSelector	RGBtoRGB
ColorTransformationEnable	True
ColorTransformationValueSelector	Gain00
ColorTransformationValue	1.49823



- The CCM is available in some models only, so the actual condition shall prevail.
- The descriptions about the options of ColorTransformationValueSelector are as follows.  
Gain00 , Gain01, Gain02, and offset0 refer to the R component of red pixels.  
Gain10 , Gain11, Gain12, and offset1 refer to the G component of green pixels.  
Gain20 , Gain21, Gain22, and offset2 refer to the B component of blue pixels.

# Auto Functions and Polling Control

## Auto Function Control

Cameras support the exposure auto adjustment, gain auto adjustment, target brightness setting, etc. User can set parameter adjustment range of relevant parameters under the AutoFunctionControl , and use AutoFunctionROIControl to statistic the data in ROI area and calculate parameters in the auto adjustment modes. The detailed procedures are as follows.

Procedure:

Step 1 Set the value of AutoTargetBrightness as for the reference value of target brightness of exposure auto adjustment and gain auto adjustment. The default value is 50.

Step 2 Select the parameters that needs to enable the auto adjustment functions. Take the exposure auto adjustment as an example, set the ExposureAuto under the AcquisitionControl to Once or Continuous, as shown in the figure below.

ExposureAuto	Continuous
--------------	------------

Step 3 Set the values of AutoExposureTimeLowerLimit and AutoExposureTimeUpperLimit under the AutoFunctionControl for limiting the exposure auto adjustment range, so that the result of adjustment can be maintained in the set range.

AutoTargetBrightness	50
AutoFunctionProfile	MinimizeExposureTime
AutoGainLowerLimit	1.00000
AutoGainUpperLimit	32.00000
AutoExposureTimeLowerLimit	25.00000
AutoExposureTimeUpperLimit	5,000.00000

Step 4 After starting the image acquisition, the image brightness will be adjusted automatically when the environment brightness is changed. The target brightness value for reference is the set value of the AutoTargetBrightness . The final exposure value of image is limited by the set range of the ResultingExposureTime, as shown in the figure below.

ExposureAuto	Continuous
ExposureTime	5,000.00000 us
ResultingExposureTime	4,998.00000 us

Step 5 User can obtain the parameters in the specific ROI area by setting the AutoFunctionROIControl. The relevant parameters are shown and described in the figure and table below.

AutoFunctionROIUsageIntensity	False
AutoFunctionROICount	1
AutoFunctionROISelector	ROI1
AutoFunctionROIOffsetX	0
AutoFunctionROIOffsetY	0
AutoFunctionROIWidth	2,448
AutoFunctionROIHeight	2,048

## Auto Function Control

Parameter	Description
AutoFunctionROIUsageIntensity	To enable the auto function control of ROI. After enabling, it will obtain the parameters from the specific ROI area; after disabling, it will obtain the parameters from the full image for parameters calculation.
AutoFunctionROICount	To set the numbers of the ROI areas, which means the parameters obtainment can be performed in one ROI area and multiple ROI areas for calculating the auto adjustment parameters.
AutoFunctionROISelector	Select the ROI area needs to be configured. User can configure each ROI area with different values of width, height, offsetX and offsetY to adjust different range of ROI area.
AutoFunctionROIOffsetX	To set the value of offsetX.
AutoFunctionROIOffsetY	To set the value of offsetY.
AutoFunctionROIWidth	To set the value of Width.
AutoFunctionROIHeight	To set the value of Height.

Step 6 After starting the image acquisition, check the image effect. If the AutoFunctionROIUsageIntensity is enabled, the auto functions of ROI area will be valid; if it is disabled, the auto functions of ROI area will invalid, and the obtained parameters is from the full image.

	<ul style="list-style-type: none"> <li>● Currently, user can configure only one ROI area.</li> <li>● User can set auto adjustment strategies only when the exposure and gain auto adjustment functions are enabled in the AutoFunctionProfile . The MinimizeGain refers to the principle of minimum gain; the MinimizeExposureTime refers to the principle of minimum exposure.</li> <li>● The operations of gain auto adjustment and exposure auto adjustment is similar.</li> </ul>
--	---

## Parameter Polling

User can configure multiple groups of polling parameters to acquire images in the SequencerFPGAControl. This function is mainly for the scenes with multiple lighting conditions.

### Functions Supporting Polling

The functions supporting polling of camera include binning, scaling, resolution and ROI, frame rate, exposure time, gain, black level, white balance, 6-axis adjustment, etc.



The functions supporting polling may vary depending on the device model, the actual condition shall prevail.

### Functional Block Diagram

Taking 4 groups of polling parameters as an example.

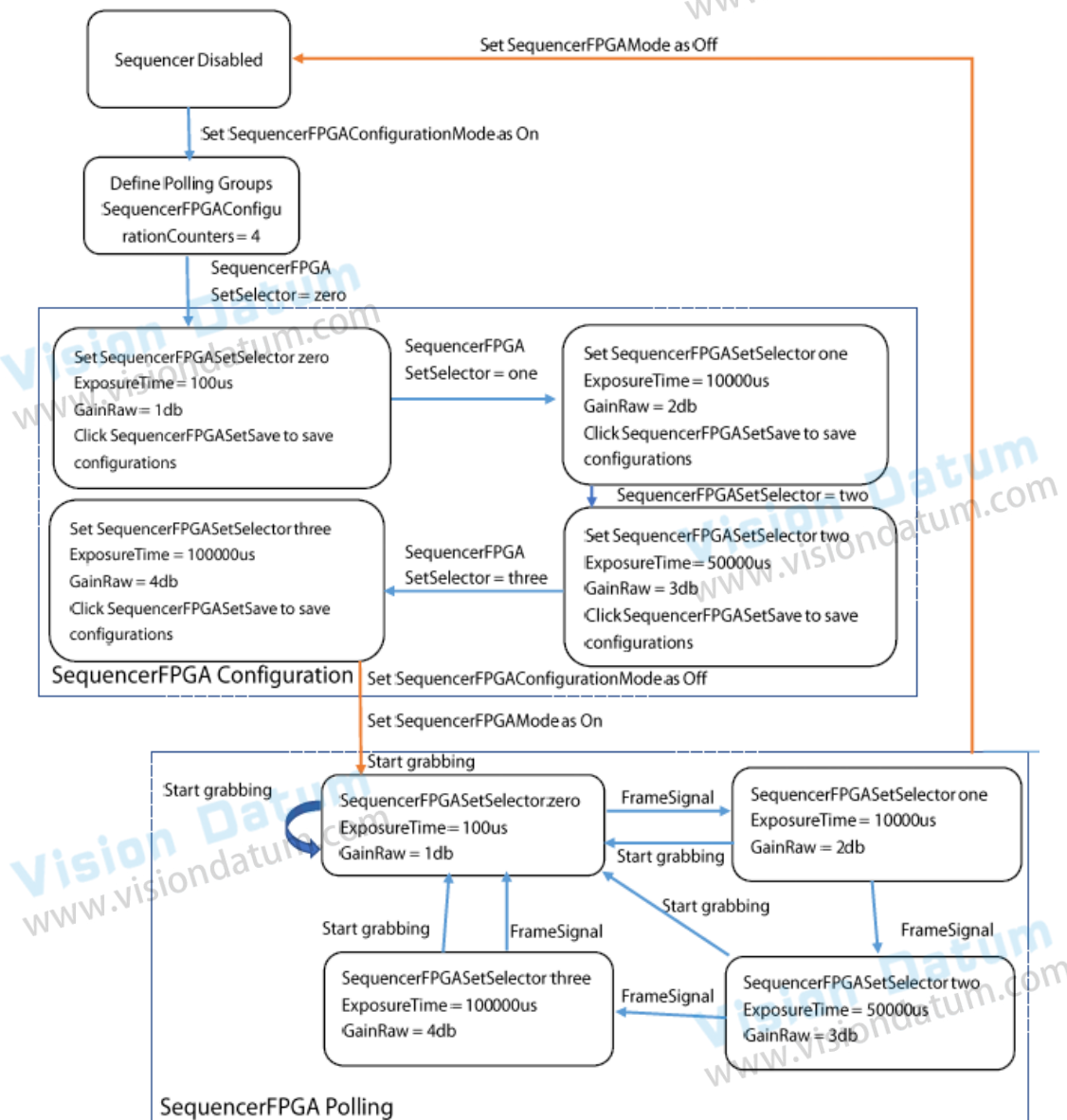

## Parameter Polling

### ■ Parameter Polling Application Instruction

Please follow the procedures below to use the parameter polling function.

Procedure:

Step 1 Set the SequencerFPGAConfigurationMode under the SequencerFPGAControl to On, as shown in the figure below.

SequencerFPGAMode	(Not Available)
SequencerFPGAConfigurationMode	On
SequencerFPGASetSave	{Command}
SequencerFPGASetLoad	{Command}
SequencerFPGAConfigurationCounters	two
SequencerFPGASetSelector	zero
SequencerFPGATriggerSource	FrameSignal

Step 2 Set the total groups of parameter polling in the SequencerFPGAConfigurationCounters. The maximum number of groups is up to 8.

Step 3 Select the certain group in the SequencerFPGASetSelector to configure its parameters.

Step 4 Configure the SequencerFPGATriggerSource to automatically execute the next set of parameters to perform image acquisition upon completion of the current parameter group execution. The default value of SequencerFPGATriggerSource is FrameSignal, that is, the parameter polling condition is frame signal. The trigger source signals can be customized by users according to the actual demands, for example, it will switch to the next group of image acquisition parameters to acquire images after receiving the user-defined trigger source signal.

Step 5 User can configure the parameters based on user's needs according to the actual supporting functions of camera. Take the exposure time setting as an example, user needs to enter the exposure time value in the ExposureTime under the AcquisitionControl. After completing the settings of each group of parameters, click Command in the SequencerFPGASetSave, and save the user-defined parameters into the selected group.

ExposureTime	5,000.00000 us
--------------	----------------

 When setting the parameters needs to be set, you shall back to the original position of parameters to set their values.

Step 6 (Recommend) After clicking the Command in the SequencerFPGASetLoad, it will load the setting values of parameters saved in the current group, which means the setting values will be displayed on the corresponding parameters. This function can facilitate users to check the setting values of parameters of the group.

Step 7 If you need to modify the values of parameters again, please repeat the Step 5. Repeat the Step 3 ~ Step 6 to set other parameter groups.

Step 8 After completing the settings, set the SequencerFPGAConfigurationMode to Off, and set the SequencerFPGAMode to On. The parameter polling function will be enabled.

Step 9 After enabling the parameter polling, every time you click the start acquiring image, the parameter polling will restart from the ZERO group.

### ■ Cautions

Please note the following cautions when using the parameter polling.

- The parameter polling does not support the ultra-low exposure function; therefore, when you set the exposure value to the ultra-low exposure, the SequencerFPGAMode cannot be enabled.
- You should complete the settings of PixelFormat and ReverseY before enabling the parameter polling function. When running the polling function, the pixel format and mirroring function cannot be changed.

## CHAPTER 8 Other Functions

### Event Monitor

The event monitoring function can record and output the information and status of cameras when it meets some specific requirements. User can select the event type for checking and timestamp for reporting in the parameters under the EventControl. The event types are shown in the figure and table below.

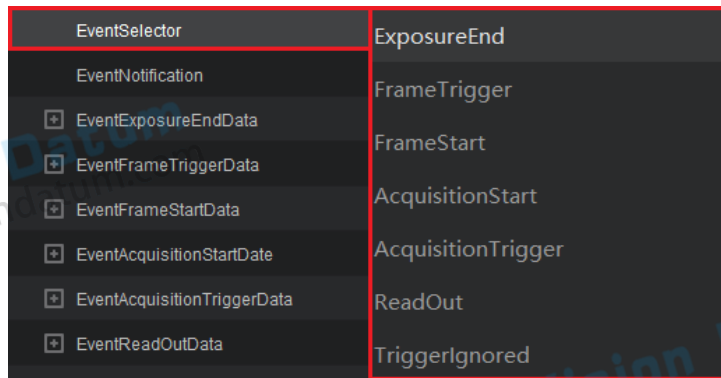

Type	Description
ExposureEnd	The exposure of one frame ends.
FrameTrigger	The camera receives the trigger signals when it is in the framestart mode.
FrameStart	Sensor starts outputting one frame data.
AcquisitionStart	Camera receives the command of starting acquisition.
AcquisitionTrigger	The camera receives the trigger signals when it is in the AcquisitionStart mode.
ReadOut	The one frame data output of sensor ends.
TriggerIgnored	The trigger signals are lost.

The detailed procedures of using EventControl are as follows.

Procedure:

Step 1 Select the event type which needs to be recorded and outputted in the EventSelector under the EventControl. Take the event type of ExposureEnd as an example, set the EventNotification to On to enable it.

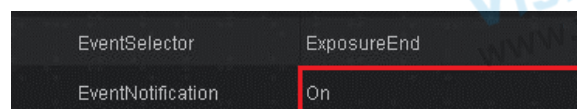

Step 2 Click "Event" in the menu bar, and click Message channel events. As shown in the figure below.

Step 3 If the behavior of camera meets the specific condition of the selected event type, the dialog box will display the event notification and timestamp. Some notifications only appear when the camera is acquiring images, as shown in the figure below.

i

- Whether camera supports the event monitoring function depends on the device model and firmware version. The actual condition shall prevail.
- The supported event types across the different cameras or different firmware versions may vary. The actual condition shall prevail.

## Counter and Timer

### Counter

The options of CounterSelector are described in the table below.

CounterSelector	Counter0
CounterResetSource	Counter1

Option	Description
Counter0	The statistics of the number of external triggers.
Counter1	The statistics of the number of output frames of camera.

There are three ways to reset the counter, as shown in the figure below.

CounterResetSource	Off
CounterEventSource	SoftwareSignal0
CounterReset	Line1
TimerSelector	Line2
TimerTriggerSource	

When you set the CounterResetSource to the SoftwareSingl0, you need to click the Command in the right side of CounterReset, as shown in the figure below.

CounterReset	{Command}
--------------	-----------

If you need the counter to display on the client, please follow the procedures below.

Procedure:

Step 1 Set the GevGVSPExtendedIDMode under the TransportLayerControl to On, as shown in the figure below.

GevGVSPExtendedIDMode	On
-----------------------	----

Step 2 Click Settings on the lower right corner, and select the DisplayChunkData, as shown in the figure below.



Step 3 Set the ChunkModeActive under the ChunkDataControl to True

Step 4 Set the ChunkSelector to Counter0Value or Counter1Value, and set the ChunkEnable to True, as shown in the figure below.

ChunkSelector	Counter0Value
ChunkEnable	Counter1Value

Step 5 When you start streaming or acquiring images, the upper left and ChunkCounter0Value and ChunkCounter1Value under the ChunkDataControl will display the actual value of counter.

ChunkCounter0Value Value:4  
 ChunkCounter1Value Value:134

ChunkCounter0Value	4
ChunkCounter1Value	134

## Counter and Timer

### ■ Timer

The camera currently supports only one timer Timer0 , and the trigger source of the timer can only be the ExposureStart. User can select the activation condition of the trigger source in the TimerTriggerActivation, including rising edge, falling edge and any edge.

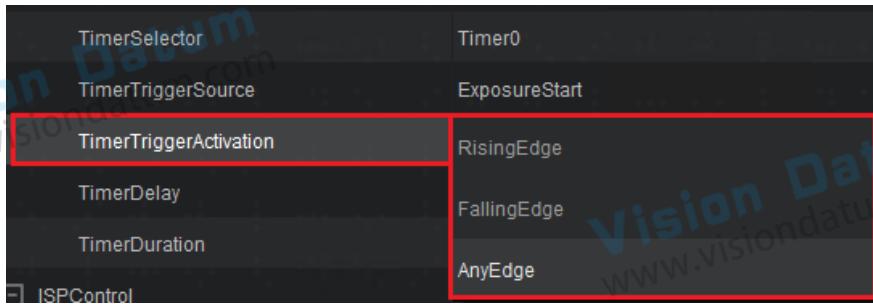

User can configure the values of the pulse signals generated by each activation condition in the TimerDelay and TimerDuration, as shown in the figures below.

Diagram of pulse signals in rising edge:

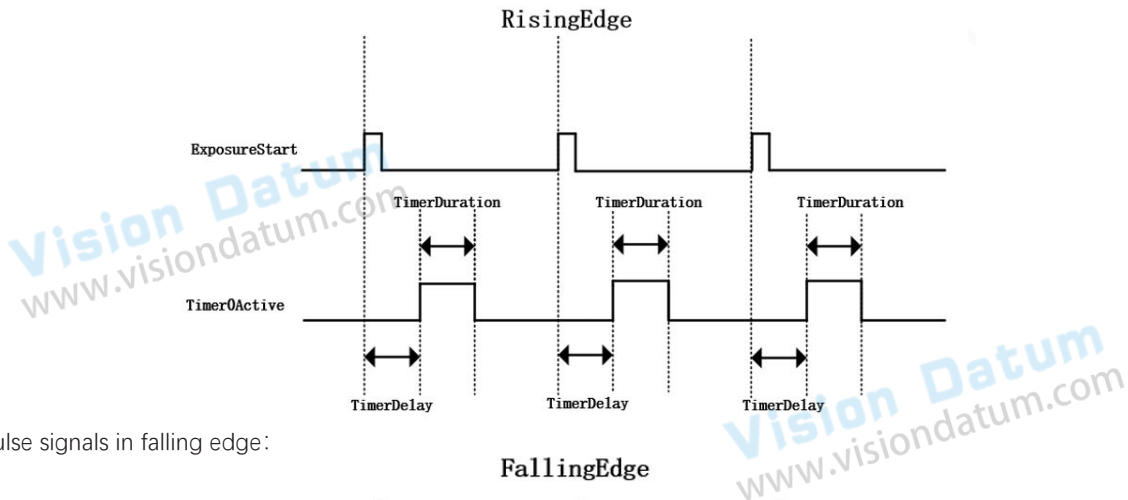

Diagram of pulse signals in falling edge:

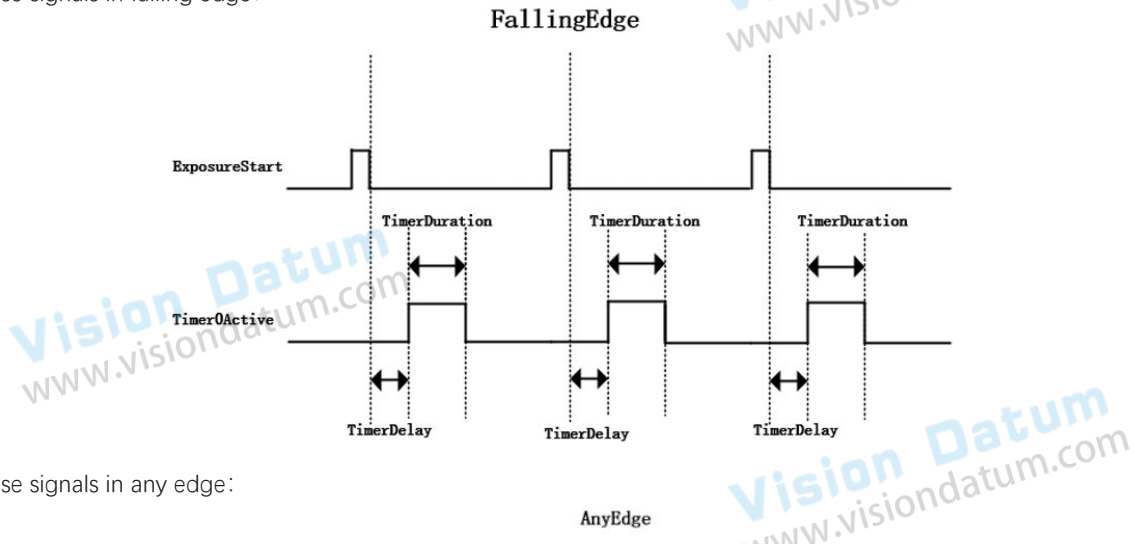
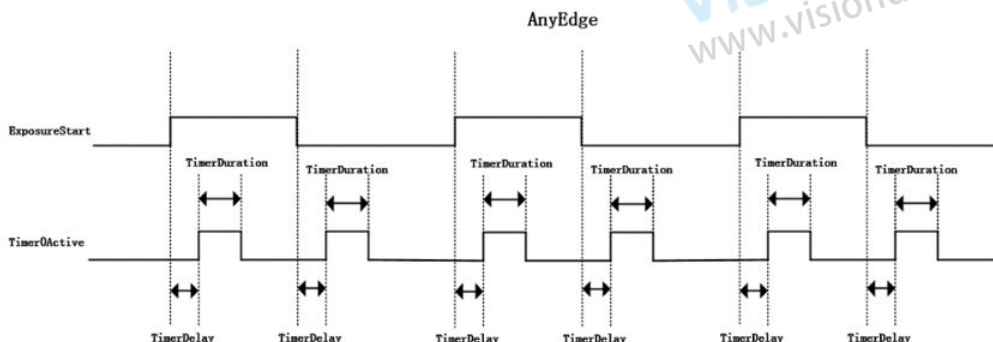

Diagram of pulse signals in any edge:



## Counter and Timer

### Counter as External Trigger Source

When the TriggerSource is set to Counter0, the external trigger signals are combined into one signal, so that a high-frequency trigger signals is combined into an external trigger signal having a frequency suitable for the camera.

Procedure:

- Step 1 Set the TriggerSelector under the AcquisitionControl to the AcquisitionStart or FrameStart.
- Step 2 Set the TriggerMode to the On.
- Step 3 Set the TriggerSource to the Counter0.

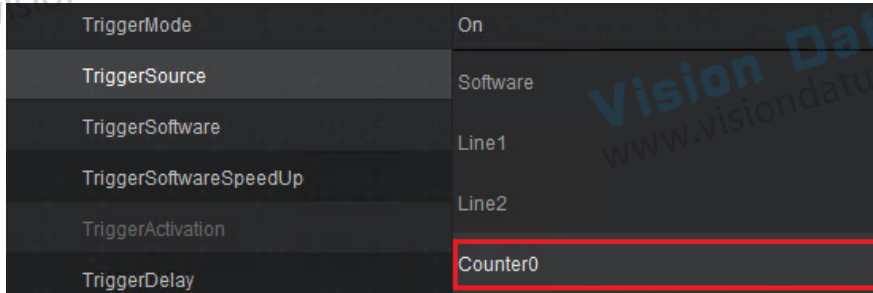

**i** The option Counter0 is available only in some device models. The actual condition shall prevail.

After selecting the Counter0 as the external trigger source, the property of CounterControl will appear behind the CounterAndTimerControl, as shown in the figure below. The parameters are described in the table below.



Parameter	Description
CounterTriggerSource	For selecting the external trigger source, including line1 and line2.
CounterTriggerActivation	For selecting the activation condition of trigger signal, including rising edge and falling edge.
CounterValue	For configuring how many external triggers pulse signals need to be combined into one signal to output.
CounterCurrentValue	For recording the serial number of the input pulse signal which is to be combined. The serial number is starting from the zero.

To reset the CounterCurrentValue, you need to set the ResetSource to the Software, and click Command in the ResetCounterCurrentValue.

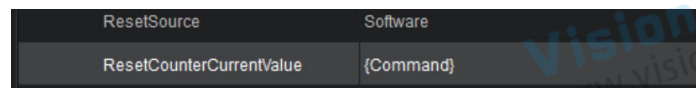

**i** Configure the parameters to start/reset/shutdown Counter0, and it will merge input pulse signals into one signal to the sensor to perform exposure trigger according to the value which user set in the CounterValue.

Diagram of external trigger signals merging:

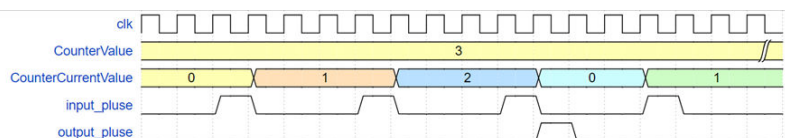

## User Set

A configuration set is a group of values that contains all of the parameter settings needed to control the camera. There are three basic types of configuration sets: the active set, the default set, and user sets.

**Active Set:** The active set is the camera's current parameter settings. It is located in the camera's volatile memory and the settings are lost if the camera is reset or if power is switched off.

**Default Set:** The default set is the camera's factory optimized configuration. It is saved in a permanent file in the camera's non-volatile memory. It is not lost when the camera is reset or switched off.

**User Sets:** There are two reserved areas in the camera's non-volatile memory available for saving configuration sets. A configuration set saved in a reserved area is commonly referred to as a "user set" .

The two available user sets are called User Set 1 and User Set 2.

### Save User-Defined Parameters

Procedure:

Step 1 After the parameters are set, select the user-defined configuration set (except the Default) in the UserSetSelector, as shown in the figure below.

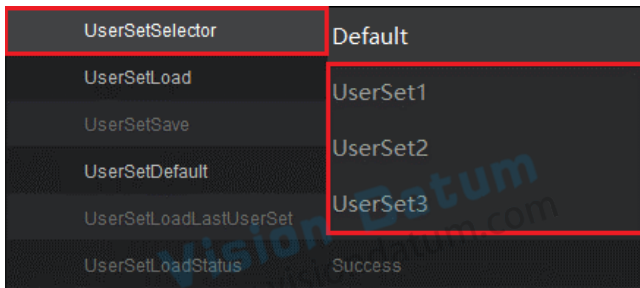

Step 2 Click UserSetLoad, as shown in the figure below.

### Load User-Defined Parameters

Procedure:

Step 1 Select the user-defined configuration set to be loaded in UserSetSelector.

Step 2 Click User Set Load, as shown in the figure below.

### User Set Default

User can select the configuration group as the default one in the UserSetDefault. After restarting the device, it will automatically load the configuration group which you selected.

- The UserSetLoadLastUserSet displays the name of loaded configuration group.
- The UserSetLoadStatus displays whether the configuration group is loaded successfully.

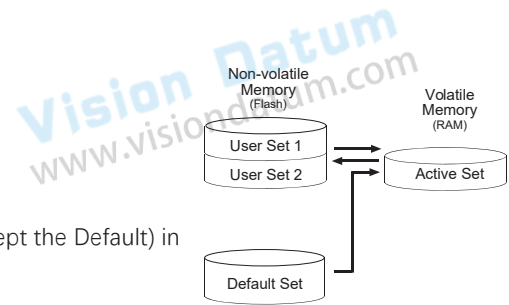

## Chunk Data Control

The ChunkDataControl is for embedding the information behind the image data. This function can only be valid when the parameter of GevGVSPExtendedIDMode under the TransportLayerControl is configured as On.

	The property and parameter may vary depending on the device model.
--	--

Parameter	Description	Read / Write
ChunkModeActive	After enabling, the chunk data will be embedded behind the image data. It is disabled by default.	Read and Write
ChunkSelecto	To select the channel of Chunk control.	Read and Write
ChunkEnable	To enable the Chunk channel. It is disabled by default.	Read and Write
ChunkCounter0Value	Counter0	Read Only
ChunkCounter1Value	Counter1	Read Only

## File Open and File Save

This section introduces how to open or save the configuration file. The suffix of the saved file is ".mvcfg". Before opening or saving the configuration file, please click Stop Streaming.

- Load User-defined Configuration File:

Click File > Open, the file selection window will pop up. Select and load the configuration file to complete the configuration loading. Click File > Open Recent, it will display the recent loaded configurations. User can select and load the configurations as needed.

- Save User-defined Configuration File:

Click File > Save. If it is the first time to save the configuration file, the client will suggest you to name the file. Click File > Save As. User can save and rename the current loaded configurations as another file.

## Multi-Cast

The multi-cast function can permit multiple host computers to access the same device. After enabling this function, the device can be connected with the permissions of control and data receiving and be connected by multiple devices with the permission of data receiving. The device has two kinds of multi-cast modes.

- Controller and Data Receiver: It can control the device to streaming, and read and modify the parameters of device
- Data Receiver: It can control the device to streaming and read the parameters of device, but it cannot modify the parameters of device.

The detailed procedures of enabling the multi-cast function are as follows.

Procedure:

Step 1 Select the device in the device list, right click the device and select the Multicast Settings, as shown in the figure below.

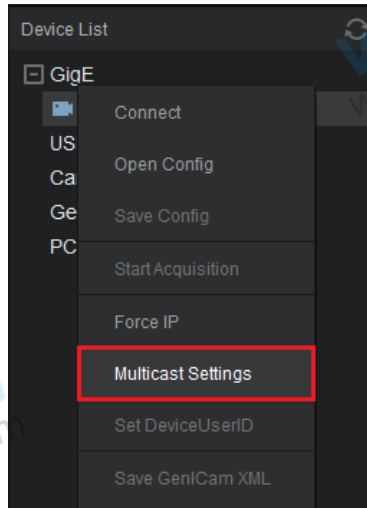

Step 2 If the device is in the available mode, user can select the Controller and Data Receiver or Data Receiver to enable the multi-cast function in the Multicast Setting interface, as shown in the figure below. If the device is in the connection mode, user can only enable multi-cast function with the mode of Controller and Data Receiver, as shown in the figure below.

Multicast settings interface in the available mode:

Multicast settings interface in the connection mode:

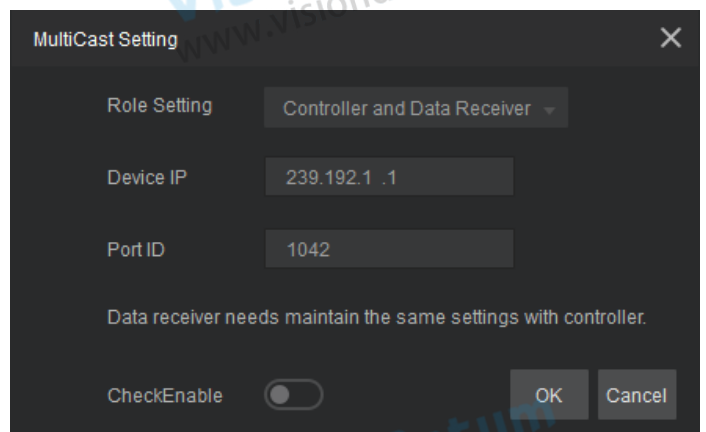

Step 3 The IP address of multi-cast function can only be the D-type Ip address. If the set IP address is invalid, the client will prompt saying "Multicast settings incorrect! The camera will be connected in non-multicast mode".

Step 4 The value range of port number of multi-cast function is 0~65535. Please make sure the entered port number is not occupied.

Step 5 Click OK to enable the multi-cast function.

## Device Control

User can check device information, protocol version, customized ID, device temperature, device reset, etc. in the DeviceControl. The descriptions of parameters under the DeviceControl are shown in the table below.

Parameter	Read /Write	Description
DeviceType	Read Only	The type information of device.
DeviceScanType	Read Only	The scan mode of device's sensor.
DeviceVendorName	Read Only	The name of the manufacturer.
DeviceModelName	Read Only	The model information of the device.
DeviceManufacturerInfo	Read Only	The manufacturer information.
DeviceVersion	Read Only	The version of the device.
DeviceFirmwareVersion	Read Only	The firmware version of the device.
DeviceSerialNumber	Read Only	The serial number of the device.
DeviceUserID	Read and Write	The device ID can be customized and it is empty by default.
DeviceTLType	Read Only	The protocol type in the version number of GEV.
DeviceTLVersionMajor	Read Only	The major version information in the GEV version.
DeviceTLVersionMinor	Read Only	The minor version information in the GEV version.
DeviceMaxThroughput	Read Only	Maximum operating flow rate of device (Kbps).
DeviceCharacterSet	Read Only	The string set of devices.
DeviceReset	Read and Write	Click this button to perform the soft reboot and parameter reset.
DeviceTemperatureSelector	Read and Write	For selecting the temperature sensor of device to read the temperature information of sensor or motherboard.
DeviceTemperature	Read Only	To display the temperature of the selected components in DeviceTemperatureSelector.
FanSelector	Read and Write	For selecting fan.
FanMode	Read and Write	To enable the fan.
FanSpeed	Read and Write	The speed setting of fan.
FanRpm	Read Only	To display the speed detection value of fan.
SensorTargetTemperature	Read and Write	The target temperature of TEC refrigeration.
DeviceRegistersIsBigEndian	Read Only	The byte order of device registers.
DeviceDevelopData	Read and Write	The command port for developing and debugging.
DeviceTLVersionSelector	Read Only	The version information of GEV.

## Transport Layer Control

The `TransportLayerControl` property includes some parameters of network modes and performance information which can be configured. The parameters may vary depending on the camera models.

Parameter	Read /Write	Description
<code>PayloadSize</code>	Read Only	The total size of payload (B) including end-of-line, end-of-frame, or other stamp data.
<code>GevActiveLinkCount</code>	Read Only	The number of valid links.
<code>GevInterfaceSelector</code>	Read and Write	To select the physical network interface.
<code>GevLinkSpeed</code>	Read and Write	The transmission speed of the network interface.
<code>GevMACAddress</code>	Read Only	The MAC address of the network interface.
<code>GevSupportedOptionSelector</code>	Read and Write	To check whether the GEV is valid by selecting it.
<code>GevSupportedOption</code>	Read Only	To display the status of selected option in the <code>GevSupportedOptionSelector</code> .
<code>GevCurrentIPConfigurationLLA</code>	Read Only	To display whether the IP address of camera is obtained through the dynamic link address. It is enabled by default.
<code>GevCurrentIPConfigurationDHCP</code>	Read and Write	After enabling, the IP address is loaded obtained by DHCP. It is disabled by default.
<code>GevCurrentIPConfigurationPersistentIP</code>	Read and Write	After enabling, the static IP address will be loaded. It is enabled by default.
<code>GevCurrentIPAddress</code>	Read Only	The IP address of the network interface.
<code>GevCurrentSubnetMask</code>	Read Only	The subnet mask of the network.
<code>GevCurrentDefaultGateway</code>	Read Only	The gateway IP address of the network interface.
<code>GevIPConfigurationStatus</code>	Read Only	The set mode of IP address.
<code>DeviceManifestPrimaryURL</code>	Read Only	The primary URL of device manifest.
<code>DeviceManifestSecondaryURL</code>	Read Only	The secondary URL of device manifest.
<code>GevNumberOfInterfaces</code>	Read Only	The number of physical network interface which device supports.
<code>GevPersistentIPAddress</code>	Read and Write	To configure the static IP address of the network interface.
<code>GevPersistentSubnetMask</code>	Read and Write	To configure static subnet mask of network interface.
<code>GevPersistentDefaultGateway</code>	Read and Write	To configure the static gateway of the network interface.
<code>GevMessageChannelCount</code>	Read Only	The number of event channels which device supports
<code>GevStreamChannelCount</code>	Read Only	The number of stream channels.
<code>GevHeartbeatTimeout</code>	Read and Write	To set the timeout value of heartbeat packet. Within the set timeout value, if no heartbeat response is received from the camera SDK, the camera occupation status will be cleared. This function is for checking whether the camera is working normally.
<code>GevTimestampTickFrequency</code>	Read Only	To display the number of times timestamp marks in one second (Hz).
<code>GevTimestampControlLatch</code>	Read and Write	After enabling, it will lock the counter of timestamp into the <code>GevTimestampValue</code> .
<code>GevTimestampControlReset</code>	Read and Write	After enabling, it will restore the counter of timestamp.
<code>GevTimestampValue</code>	Read Only	To display the latched value of timestamp.
<code>GevGVCPExtendedStatusCodesSelector</code>	Read and Write	To set the GigE version to control extended status codes.
<code>GevGVCPExtendedStatusCodes</code>	Read and Write	To enable the extended status codes production. It is disabled by default.
<code>GevGVCPPendingAck</code>	Read and Write	To enable the answer command generation. It is enabled by default.
<code>GevGVCPHeartbeatDisable</code>	Read and Write	To enable the heartbeat. It is disabled by default.
<code>GevGVCPPendingTimeout</code>	Read and Write	To display the delay time before the camera returns the response command.
<code>GevPrimaryApplicationSwitchoverKey</code>	Read Only	To control the secret key which is used to verify the switch request of the main application.
<code>GevGVSPExtendedIDMode</code>	Read and Write	To enable the ID mode. It is disabled by default.

## Transport Layer Control

Parameter	Read /Write	Description
GevCCP	Read and Write	To set the access permission.
GevPrimaryApplicationSocket	Read Only	The port number which is used to connect the port of host computer.
GevPrimaryApplicationIPAddress	Read Only	To set the IP address for connecting the host computer.
GevMCPHostPort	Read and Write	To set the device port for sending messages. Entering "0" will disable the message channel.
GevMCDA	Read and Write	To control the target IP address of the message channel.
GevMCTT	Read and Write	To set the transmission timeout value in milliseconds.
GevMCRC	Read and Write	To set the number of retransmissions allowed when the message channel transmits the timeout information.
GevMCSP	Read Only	To display the source port of message channel.
GevStreamChannelSelector	Read and Write	To select the device stream channel.
GevSCPInterfaceIndex	Read and Write	To select the network link index.
GevSCPHostPort	Read and Write	To set the host computer port of stream channel. Entering "0" will disable the stream channel.
GevSCPSFireTestPacket	Read and Write	Every time this function is enabled, a test packet is sent.
GevSCPSPDoNotFragment	Read and Write	After enabling, the status will be displayed in the unfragmented bit of IP header of each stream data packet to prevent fragmentation of packet in stream channel.
GevSCPSPacketSize	Read and Write	To set the maximum packet size during transmitting the data of camera.
GevSCPDSwitch	Read and Write	To enable the transmission delay among data packets. It is disabled by default. When this function is disabled, the value of GevSCPDP shall prevail; when this function is enabled, the value of SCPDSwitchValue shall prevail.
SCPDSwitchValue	Read and Write	To set the value of SCPD. The jumbo frame is recommended.
AdaptiveStreaming	Read and Write	If your network is not good enough, this function will adjust the SCPD value automatically without affecting the frame rate. This function is enabled by default.
RealSCPD	Read Only	If AdaptiveStreaming is enabled, this parameter will display the current SCPD value.
GevSCPDP	Read and Write	To set the transmission delay value of each data packet.
GevSCDA	Read and Write	To set the target IP address for receiving the stream data.
GevSCSP	Read Only	To display the source port of stream channel.
FrameTriggerCount	Read Only	To return the number of trigger signals which camera receives. The trigger signals include the external trigger signal and software trigger signal.
FrameTriggerLostCount	Read Only	To return the number of trigger signals which camera losses. The trigger signals include the external trigger signal and software trigger signal.
SensorTriggerCount	Read Only	To count the signals for acquiring images which sensor receives. It can count the image acquiring signals which operated in three modes including free run, external trigger, and software trigger.
SensorFrameCount	Read Only	To count output frame rate of sensor. It can count frame rate of sensor which operates in three modes including free run, external trigger, and software trigger.
FrameTriggerCountReset	Read and Write	To reset the counter of parameters, such as FrameTriggerCount, FrameTriggerLostCount, SensorTriggerCount, SensorFrameCount.

## CHAPTER 9 Technical Support

### Technical Support

If you need advice about your camera or if you need assistance troubleshooting a problem with your camera, it's highly recommended to describe your issue in details and contact us via E-mail at [support@visiondatum.com](mailto:support@visiondatum.com)

It would be helpful if you can fill-in the following table and send to us before you contact our technical support team.

Camera Model:		Camera's SN:	
Describe the issue in as much detail as possible:			
If known, what's the cause of the issue?			
How often did/does the issue occur?			
How severe is the issue?			
Parameter set	Please connect the camera directly to PC and use iCentral to make note of the parameter when the issue occurred.		

Hangzhou Vision Datum Technology Co., Ltd

No.8 Xiyuan 9th Road, West Lake District Hangzhou Zhejiang 310030 China  
Tel: 86-571-86888309  
[www.visiondatum.com](http://www.visiondatum.com)

For Research Use Only ©2025 Hangzhou Vision Datum Technology Co., Ltd.  
All rights reserved. All trademarks are the property of Hangzhou Vision Datum Technology Co., Ltd.



微图视觉  
Vision Datum