

- 1.3MP @85 fps
- Adopts GigE interface and max. transmission distance of 100 meters without relay
- Compatible with GigE Vision Protocol, GenICam Standard, and the third-party software based on these protocol and standard
- Support Windows、Linux
- 64 MB local memory for burst transmission and retransmission



**Applied range** • Defect Detection • Surface Patch Detection • Visual Positioning • Size Measuring • QR Code Reading • VR/AR • Logistics

Camera	Mars1300S-85gm/gc
Resolution [H*V]	1280 x 1024
Sensor	SS
Sensor Size	1/2.7"
Sensor Technology	Global, CMOS
Pixel Size [ $\mu\text{m}$ ]	4.0 x 4.0
Frame Rate [fps]	85
Data Bit	8bit / 10bit
Exposure Time	10 $\mu\text{s}$ ~1s
Dynamic Range	60dB
Mono/Color	Mono/Color
Image Format	Monochrome: Mono8/10/10Packed/12/12Packed Color: Mono8, BayerRG8/10/10packed, BayerGB8/10/10Packed, YUV422packed
Interface	GigE
Synchronization	Via hardware trigger、software trigger or free run mode
Programmable Control [ISP]	Image resolution、RGB gain、Exposure time、Contrast ratio、Gamma form、Image rollovers、Raw、LUT、Black level correction
Housing Size [l*w*h]	29.0 x 29.0 x 42.0 mm (88g)
Operating Temperature	-30~70 ° C (Storage), 0~50° C (Working)
Lenses Mount	C-Mount
Digital I/O	Opto-isolated input x 1, opto-isolated output x 1, and bi-directional custom non-isolated I/O x 1
Power Input	DC 6-24V, Supporting PoE
Power Consumption	12V@ $\approx$ 3.4W
Driver	Mars Series Camera Software Suite (iCentral) or 3rd party GigE Vision Software
Operating System	Windows, Linux
Conformity	GigE Vision, GenICam

### Spectral Response

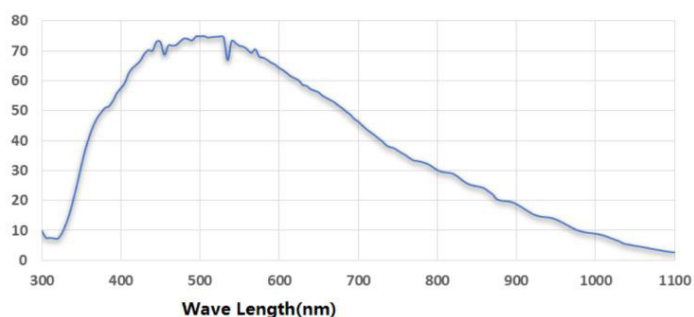

### Dimensions

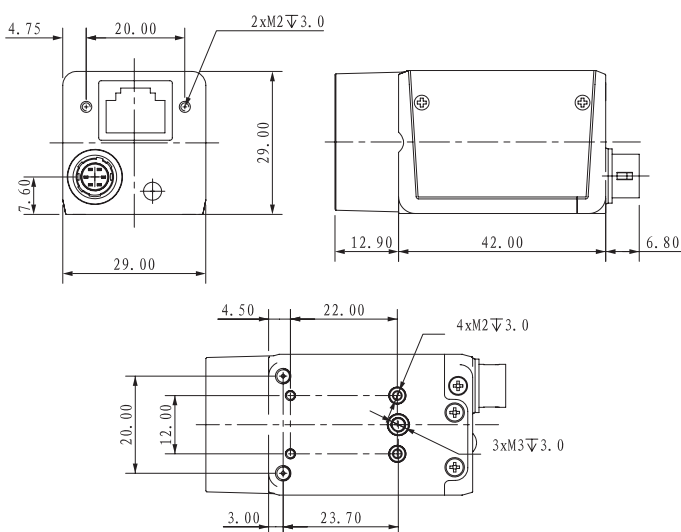

No.8, Xiyuan 9th Road West Lake District, Hangzhou 310030 China  
 Tel: 86-571-86888309, 86-571-86888307  
 Web: [www.visiondatum.com](http://www.visiondatum.com) Email: [market@visiondatum.com](mailto:market@visiondatum.com)

