



LEO 8192G-L14gm

- 8K @14 KHz
- Adopts GigE interface and max. transmission distance of 100 meters without relay
- Compatible with GigE Vision Protocol, GenICam Standard, and the third-party software based on these protocol and standard
- Support Windows、Linux
- Up to 512 MB local memory for burst transmission and retransmission



Applied range • Printing • Textile • Railway • Logistics • Metallurgy • Food • Pharmaceutical • Material sorting

Camera	LEO 8192G-L14gm
Resolution [H*V]	8192 × 4
Sensor Type	CMOS
Pixel Pize [μm]	5 × 5
Line Frequency [KHz]	14 kHz@Mono 8、 7 kHz@Mono 10/Mono 12、 9.4 kHz@Mono 10p/Mono 12p ; HB: 40 kHz@Mono 8、 20 kHz@Mono 10/Mono 12
Data Bit	8bit / 10bit / 12bit
Exposure Time	3μs~10ms
Dynamic Range	54.8dB
Mono/Color	Mono
Image Format	Mono 8/10/10p/12/12p
Interface	GigE
Synchronization	Via hardware trigger、software trigger or free run mode
Programmable Control [ISP]	Image resolution、RGB gain、Exposure time、Gamma form、Image rollovers、Raw、LUT、Black level correction
Housing Size [l*w*h]	80.0 × 80.0 × 46.3 mm (465g)
Operating Temperature	-30~80 ° C (Storage), -20~56° C (Working)
Lenses Mount	M72*0.75, BFL 12 mm
Digital I/O	Configurable output and input × 4, supports single-end/differential
Power Input	DC 12-24V
Power Consumption	12V @12.4W
Driver	LEO Series Camera Software Suite (iDatum) or 3rd party GigE Vision Software
Operating System	Windows, Linux
Conformity	GigE Vision, GenICam

Spectral Response

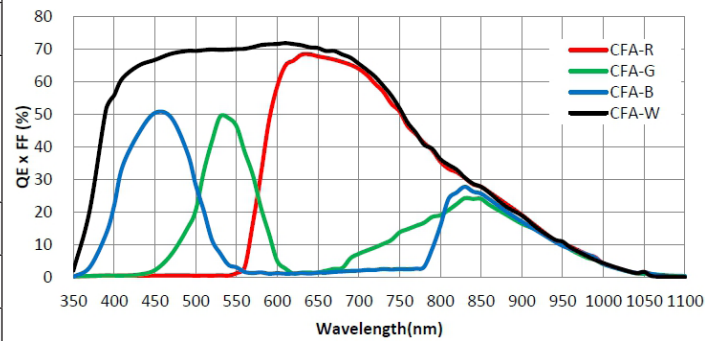

Dimensions

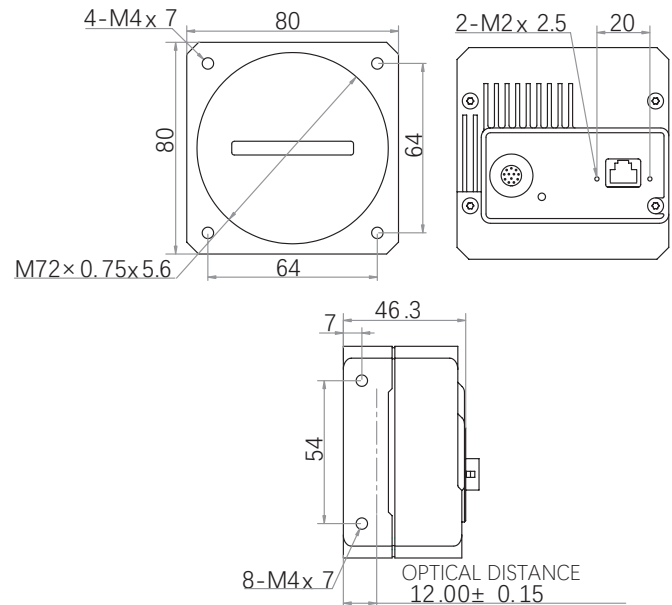

No.8, Xiyuan 9th Road West Lake District, Hangzhou 310030 China
Tel: 86-571-86888309, 86-571-86888307
Web: www.visiondatum.com Email: market@visiondatum.com

