

BTL SERIES

NEW



PRODUCT FEATURES

1. Optimized for 1/2.5"~1.1" C-Mount cameras;
2. Largest FOV from 26mm upto 300mm;
3. Excellent resolution for high pixel cameras;
4. Low distortion, good telecentricity, big aperture and big depth of field for high end application.

NAMING RULES

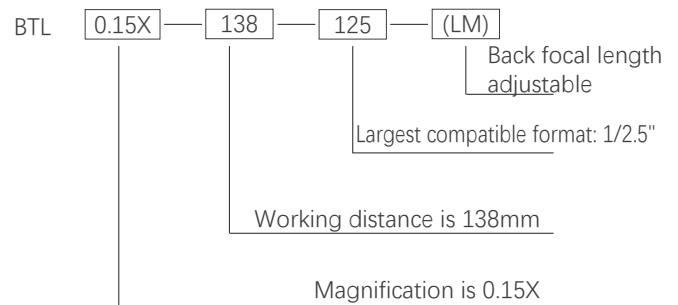

OVERVIEW

BTL Series Magnification Crosstab

| Sensor Size FOV (mm) Mag X | 1/2.5" BTL-125 | 1/2" BTL-12 | 1/1.8" BTL-118 | 2/3" BTL-23 | 1" BTL-H1 | 1.1" BTL-H1.1 | 4/3" BTL-H2 | 1.75" BTL-175 | 2" BTL-21 | 39mm BTL-71M | 44mm BTL-FF | 59mm BTL-16K | WD (mm) |
|-------------------------------|-------------------|----------------|-------------------|----------------|--------------|------------------|----------------|------------------|--------------|-----------------|----------------|-----------------|---------|
| 26 | 0.277 | 0.308 | 0.346 | 0.438 | 0.638 | 0.708 | 0.923 | 1.115 | / | / | / | / | 73 |
| 36 | 0.2 | 0.222 | 0.25 | 0.317 | 0.46 | 0.511 | 0.67 | 0.806 | 0.917 | 1.083 | / | / | 110 |
| 42 | 0.171 | 0.19 | 0.214 | 0.271 | 0.395 | 0.438 | 0.571 | 0.69 | 0.786 | 0.929 | 1.048 | / | 118 |
| 48 | 0.15 | 0.167 | 0.188 | 0.238 | 0.346 | 0.383 | 0.5 | 0.604 | 0.688 | 0.813 | 0.92 | / | 128 |
| 56 | 0.129 | 0.143 | 0.161 | 0.204 | 0.296 | 0.329 | 0.429 | 0.518 | 0.589 | 0.696 | 0.785 | / | 138 |
| 64 | 0.113 | 0.125 | 0.14 | 0.178 | 0.258 | 0.287 | 0.375 | 0.453 | 0.516 | 0.609 | 0.688 | / | 189 |
| 72 | 0.1 | 0.111 | 0.125 | 0.158 | 0.231 | 0.256 | 0.333 | 0.403 | 0.458 | 0.542 | 0.611 | / | 178 |
| 80 | 0.09 | 0.1 | 0.113 | 0.142 | 0.206 | 0.23 | 0.3 | 0.363 | 0.41 | 0.488 | 0.55 | / | 228 |
| 90 | 0.08 | 0.089 | 0.1 | 0.127 | 0.184 | 0.204 | 0.267 | 0.322 | 0.367 | 0.433 | 0.489 | 0.656 | 208 |
| 100 | 0.072 | 0.08 | 0.09 | 0.114 | 0.166 | 0.184 | 0.24 | 0.29 | 0.33 | 0.39 | 0.44 | / | 258 |
| 120 | 0.06 | 0.067 | 0.075 | 0.095 | 0.138 | 0.153 | 0.2 | 0.242 | 0.275 | 0.325 | 0.367 | / | 280 |
| 150 | 0.048 | 0.053 | 0.06 | 0.076 | 0.11 | 0.123 | 0.16 | 0.193 | 0.22 | 0.26 | 0.293 | 0.393 | 300 |
| 190 | 0.038 | 0.042 | 0.047 | 0.06 | 0.087 | 0.097 | 0.126 | 0.153 | 0.174 | 0.205 | 0.23 | 0.311 | 330 |
| 240 | 0.03 | 0.033 | 0.038 | 0.048 | 0.069 | 0.077 | 0.1 | 0.121 | 0.138 | 0.163 | 0.183 | 0.246 | 410 |
| 300 | 0.024 | 0.027 | 0.03 | 0.038 | 0.055 | 0.061 | 0.08 | 0.097 | 0.11 | 0.13 | 0.147 | 0.197 | 465 |
| Mount | C | C | C | C | C | C | C/F | F | F | F | F | M72 | |

BTL-FF SERIES

44mm



| Model No. ¹ | Optical specs | | | | | | | | | | Mechanical specs | | |
|------------------------|---------------|----------|----------------------|------------------------|------|---------------|-----------------------|---------------------------------|-------------------------------------|-----------------------|------------------|------------|-------------|
| | FOV (Φmm) | Mag. (x) | WD (mm) ² | Max. Sensor Size (Φmm) | F/# | MTF30 (lp/mm) | DOF (mm) ³ | Distortion (% max) ⁴ | Telecentricity (° max) ⁵ | I/O (mm) ⁶ | Length (mm) | Mount | Weight (kg) |
| BTL-1.048X-118-FF(LM) | 42 | 1.048 | 118±3 | 44(35mm Full) | 17.2 | >45 | ±0.7@F20 | <0.1 | <0.1 | 366±3 | 201.1 | F or other | 0.8 |
| BTL-0.92X-128-FF(LM) | 48 | 0.92 | 128±3 | 44(35mm Full) | 17.2 | >45 | ±0.9@F20 | <0.1 | <0.1 | 389±3 | 214.6 | F or other | 0.8 |
| BTL-0.92X-138-FF(LM) | 48 | 0.92 | 138±3 | 44(35mm Full) | 25.9 | >30 | ±1.2@F25.9 | <0.1 | <0.1 | 384±3 | 199.6 | F or other | 0.9 |
| BTL-0.785X-138-FF(LM) | 56 | 0.785 | 138±3 | 44(35mm Full) | 14.8 | >55 | ±1.2@F20 | <0.1 | <0.1 | 422±3 | 237.1 | F or other | 1.1 |
| BTL-0.688X-189-FF(LM) | 64 | 0.688 | 189±3 | 44(35mm Full) | 25.9 | >30 | ±2.1@F25.9 | <0.1 | <0.1 | 461±3 | 225.6 | F or other | 1.2 |
| BTL-0.611X-178-FF(LM) | 72 | 0.611 | 178±3 | 44(35mm Full) | 12.9 | >65 | ±2.1@F20 | <0.1 | <0.1 | 494±3 | 269.6 | F or other | 1.4 |
| BTL-0.55X-228-FF(LM) | 80 | 0.55 | 228±4 | 44(35mm Full) | 25.9 | >30 | ±3.4@F25.9 | <0.1 | <0.1 | 534±4 | 259.5 | F or other | 1.9 |
| BTL-0.489X-208-FF(LM) | 90 | 0.489 | 208±3 | 44(35mm Full) | 11.5 | >65 | ±3.3@F20 | <0.1 | <0.1 | 549±3 | 294.6 | F or other | 2.1 |
| BTL-0.44X-258-FF(LM) | 100 | 0.44 | 258±4 | 44(35mm Full) | 17.2 | >45 | ±4.1@F20 | <0.1 | <0.1 | 622±4 | 317.9 | F or other | 3.4 |
| BTL-0.367X-280-FF(LM) | 120 | 0.367 | 280±5 | 44(35mm Full) | 14.8 | >55 | ±5.9@F20 | <0.1 | <0.1 | 685±5 | 358.3 | F or other | 4.6 |
| BTL-0.293X-300-FF(LM) | 150 | 0.293 | 300±5 | 44(35mm Full) | 14.8 | >60 | ±9.3@F20 | <0.1 | <0.1 | 748±5 | 401.5 | F or other | 6.1 |
| BTL-0.23X-330-FF(LM) | 190 | 0.23 | 330±5 | 44(35mm Full) | 10.3 | >85 | ±15.1@F20 | <0.1 | <0.1 | 867±5 | 490.8 | F or other | 11.4 |
| BTL-0.183X-410-FF(LM) | 240 | 0.183 | 410±6 | 44(35mm Full) | 10.3 | >85 | ±23.8@F20 | <0.1 | <0.1 | 1098±6 | 641.9 | F or other | 25.9 |
| BTL-0.147X-465-FF(LM) | 300 | 0.147 | 465±6 | 44(35mm Full) | 10.3 | >85 | ±37@F20 | <0.1 | <0.1 | 1222±6 | 710.6 | F or other | 47.0 |

1. The back focal length of model with (LM) is adjustable.

2. Working distance: distance between the front end of the mechanics and the object.
Set this distance within the nominal value for maximum resolution and minimum distortion.

3. At the borders of the field depth the image can be still used for measurement.

4. Percent deviation of the real image compared to an ideal, undistorted image:
maximum (guaranteed) values are listed.

5. Maximum slope of chief rays inside the lens: when converted to milliradians, it gives the maximum measurement error for any millimeter of object displacement.
Maximum (guaranteed) values are listed.

6. I/O: distance between the sensor(image) and the object.

BTL-1.048X-118-FF(LM)

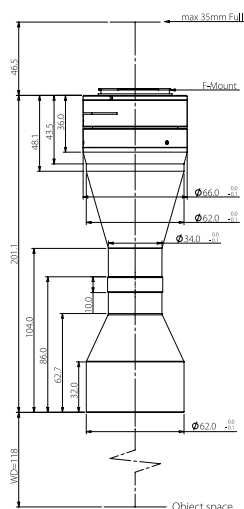

| | |
|------------------------|---------------|
| FOV(Φmm) | 42 |
| Mag.(x) | 1.048 |
| WD(mm) | 118±3 |
| Max Sensor Size(Φmm) | 44(35mm Full) |
| F/# | 17.2 |
| MTF30(lp/mm) | >45 |
| DoF(mm) | ±0.7@F20 |
| Distortion(% max) | <0.1 |
| Telecentricity(° max) | <0.1 |
| I/O(mm) | 366±3 |
| Length(mm) | 201.1 |
| Mount | F-Mount/Other |
| Weight(kg) | 0.8 |
| Field of View(mm x mm) | |
| Line-2K(20.48mm) | 19.5mm |
| Line-4K(28.67mm) | 27.4mm |
| Line-8K(40.96mm) | 39.1mm |
| 35mm Format(36.0x24.0) | 34.4x22.9 |

BTL-0.92X-128-FF(LM)

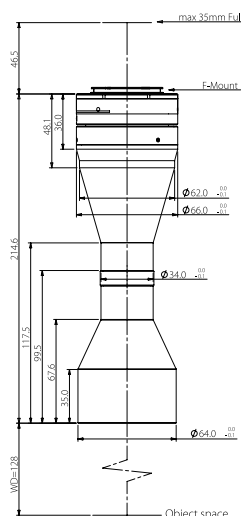

| | |
|------------------------|---------------|
| FOV(Φmm) | 48 |
| Mag.(x) | 0.920 |
| WD(mm) | 128±3 |
| Max Sensor Size(Φmm) | 44(35mm Full) |
| F/# | 17.2 |
| MTF30(lp/mm) | >45 |
| DoF(mm) | ±0.9@F20 |
| Distortion(% max) | <0.1 |
| Telecentricity(° max) | <0.1 |
| I/O(mm) | 389±3 |
| Length(mm) | 214.6 |
| Mount | F-Mount/Other |
| Weight(kg) | 0.8 |
| Field of View(mm x mm) | |
| Line-2K(20.48mm) | 22.3mm |
| Line-4K(28.67mm) | 31.2mm |
| Line-8K(40.96mm) | 44.5mm |
| 35mm Format(36.0x24.0) | 39.1x26.1 |

BTL-0.92X-138-FF(LM)

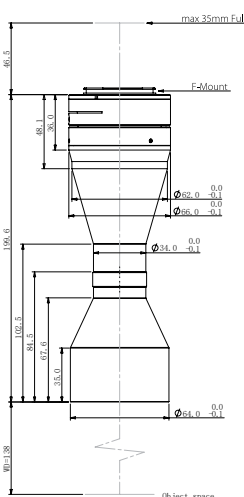

| | |
|------------------------|---------------|
| FOV(Φmm) | 48 |
| Mag.(x) | 0.920 |
| WD(mm) | 138±3 |
| Max Sensor Size(Φmm) | 44(35mm Full) |
| F/# | 25.9 |
| MTF30(lp/mm) | >30 |
| DoF(mm) | ±1.2@F25.9 |
| Distortion(% max) | <0.1 |
| Telecentricity(° max) | <0.1 |
| I/O(mm) | 384±3 |
| Length(mm) | 199.6 |
| Mount | F-Mount/Other |
| Weight(kg) | 0.9 |
| Field of View(mm x mm) | |
| Line-2K(20.48mm) | 22.3mm |
| Line-4K(28.67mm) | 31.2mm |
| Line-8K(40.96mm) | 44.5mm |
| 35mm Format(36.0x24.0) | 39.1x26.1 |

BTL-0.785X-138-FF(LM)

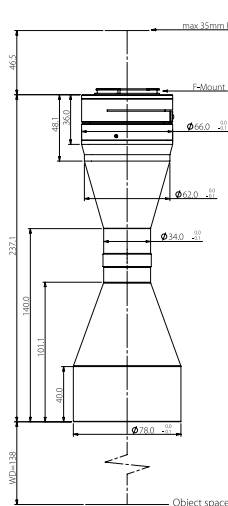

| | |
|------------------------|---------------|
| FOV(Φmm) | 56 |
| Mag.(x) | 0.785 |
| WD(mm) | 138±3 |
| Max Sensor Size(Φmm) | 44(35mm Full) |
| F/# | 14.8 |
| MTF30(lp/mm) | >55 |
| DoF(mm) | ±1.2@F20 |
| Distortion(% max) | <0.1 |
| Telecentricity(° max) | <0.1 |
| I/O(mm) | 422±3 |
| Length(mm) | 237.1 |
| Mount | F-Mount/Other |
| Weight(kg) | 1.1 |
| Field of View(mm x mm) | |
| Line-2K(20.48mm) | 26.1mm |
| Line-4K(28.67mm) | 36.5mm |
| Line-8K(40.96mm) | 52.2mm |
| 35mm Format(36.0x24.0) | 45.9x30.6 |

BTL-0.688X-189-FF(LM)

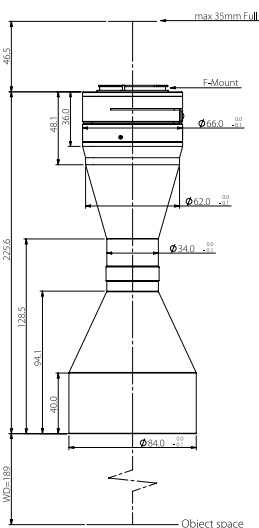

| | |
|------------------------|---------------|
| FOV(Φmm) | 64 |
| Mag.(x) | 0.688 |
| WD(mm) | 189±3 |
| Max Sensor Size(Φmm) | 44(35mm Full) |
| F/# | 25.9 |
| MTF30(lp/mm) | >30 |
| DoF(mm) | ±2.1@F25.9 |
| Distortion(% max) | <0.1 |
| Telecentricity(° max) | <0.1 |
| I/O(mm) | 461±3 |
| Length(mm) | 225.6 |
| Mount | F-Mount/Other |
| Weight(kg) | 1.2 |
| Field of View(mm x mm) | |
| Line-2K(20.48mm) | 29.8mm |
| Line-4K(28.67mm) | 41.7mm |
| Line-8K(40.96mm) | 59.5mm |
| 35mm Format(36.0x24.0) | 52.3x34.9 |

BTL-0.611X-178-FF(LM)

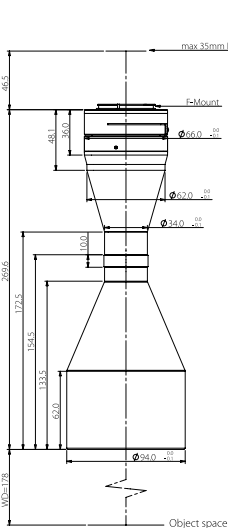

| | |
|------------------------|---------------|
| FOV(Φmm) | 72 |
| Mag.(x) | 0.611 |
| WD(mm) | 178±3 |
| Max Sensor Size(Φmm) | 44(35mm Full) |
| F/# | 12.9 |
| MTF30(lp/mm) | >65 |
| DoF(mm) | ±2.1@F20 |
| Distortion(% max) | <0.1 |
| Telecentricity(° max) | <0.1 |
| I/O(mm) | 494±3 |
| Length(mm) | 269.6 |
| Mount | F-Mount/Other |
| Weight(kg) | 1.4 |
| Field of View(mm x mm) | |
| Line-2K(20.48mm) | 33.5mm |
| Line-4K(28.67mm) | 46.9mm |
| Line-8K(40.96mm) | 67.0mm |
| 35mm Format(36.0x24.0) | 58.9x39.3 |

BTL-0.55X-228-FF(LM)

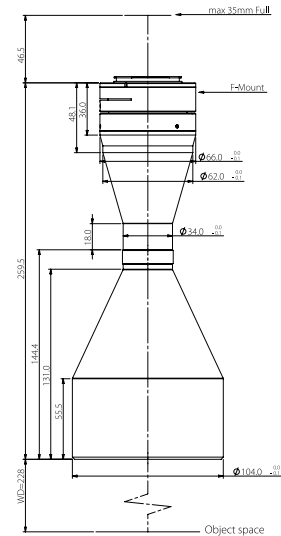

| | |
|------------------------|---------------|
| FOV(Φmm) | 80 |
| Mag.(x) | 0.550 |
| WD(mm) | 228±4 |
| Max Sensor Size(Φmm) | 44(35mm Full) |
| F/# | 25.9 |
| MTF30(lp/mm) | >30 |
| DoF(mm) | ±3.4@F25.9 |
| Distortion(% max) | <0.1 |
| Telecentricity(° max) | <0.1 |
| I/O(mm) | 534±4 |
| Length(mm) | 259.5 |
| Mount | F-Mount/Other |
| Weight(kg) | 1.9 |
| Field of View(mm×mm) | |
| Line-2K(20.48mm) | 37.2mm |
| Line-4K(28.67mm) | 52.1mm |
| Line-8K(40.96mm) | 74.5mm |
| 35mm Format(36.0x24.0) | 65.5x43.6 |

BTL-0.489X-208-FF(LM)

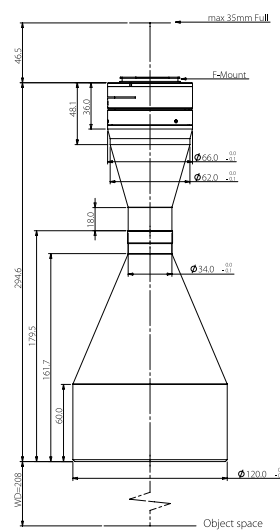

| | |
|------------------------|---------------|
| FOV(Φmm) | 90 |
| Mag.(x) | 0.489 |
| WD(mm) | 208±3 |
| Max Sensor Size(Φmm) | 44(35mm Full) |
| F/# | 11.5 |
| MTF30(lp/mm) | >65 |
| DoF(mm) | ±3.3@F20 |
| Distortion(% max) | <0.1 |
| Telecentricity(° max) | <0.1 |
| I/O(mm) | 549±3 |
| Length(mm) | 294.6 |
| Mount | F-Mount/Other |
| Weight(kg) | 2.1 |
| Field of View(mm×mm) | |
| Line-2K(20.48mm) | 41.9mm |
| Line-4K(28.67mm) | 58.6mm |
| Line-8K(40.96mm) | 83.8mm |
| 35mm Format(36.0x24.0) | 73.6x49.1 |

BTL-0.44X-258-FF(LM)

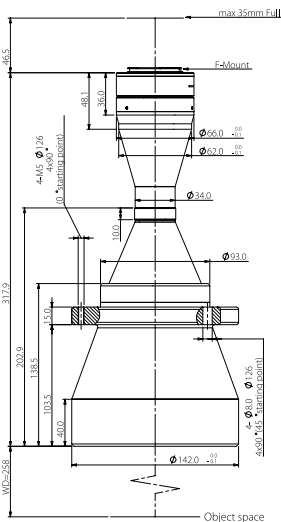

| | |
|------------------------|---------------|
| FOV(Φmm) | 100 |
| Mag.(x) | 0.440 |
| WD(mm) | 258±4 |
| Max Sensor Size(Φmm) | 44(35mm Full) |
| F/# | 17.2 |
| MTF30(lp/mm) | >45 |
| DoF(mm) | ±4.1@F20 |
| Distortion(% max) | <0.1 |
| Telecentricity(° max) | <0.1 |
| I/O(mm) | 622±4 |
| Length(mm) | 317.9 |
| Mount | F-Mount/Other |
| Weight(kg) | 3.4 |
| Field of View(mm×mm) | |
| Line-2K(20.48mm) | 46.6mm |
| Line-4K(28.67mm) | 65.2mm |
| Line-8K(40.96mm) | 93.1mm |
| 35mm Format(36.0x24.0) | 81.8x54.6 |

BTL-0.367X-280-FF(LM)

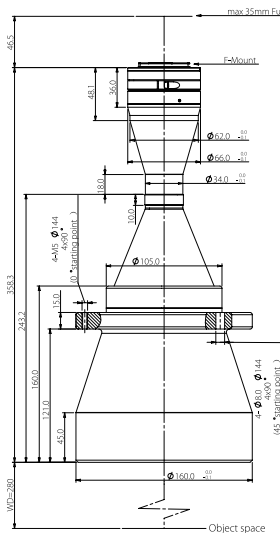

| | |
|------------------------|---------------|
| FOV(Φmm) | 120 |
| Mag.(x) | 0.367 |
| WD(mm) | 280±5 |
| Max Sensor Size(Φmm) | 44(35mm Full) |
| F/# | 14.8 |
| MTF30(lp/mm) | >55 |
| DoF(mm) | ±5.9@F20 |
| Distortion(% max) | <0.1 |
| Telecentricity(° max) | <0.1 |
| I/O(mm) | 685±5 |
| Length(mm) | 358.3 |
| Mount | F-Mount/Other |
| Weight(kg) | 4.6 |
| Field of View(mm×mm) | |
| Line-2K(20.48mm) | 55.8mm |
| Line-4K(28.67mm) | 78.1mm |
| Line-8K(40.96mm) | 111.6mm |
| 35mm Format(36.0x24.0) | 98.1x65.4 |

BTL-0.293X-300-FF(LM)

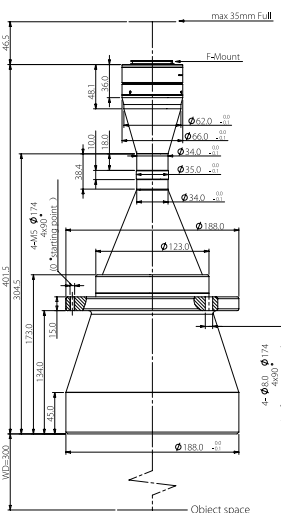

| | |
|------------------------|---------------|
| FOV(Φmm) | 150 |
| Mag.(x) | 0.293 |
| WD(mm) | 300±5 |
| Max Sensor Size(Φmm) | 44(35mm Full) |
| F/# | 14.8 |
| MTF30(lp/mm) | >60 |
| DoF(mm) | ±9.3@F20 |
| Distortion(% max) | <0.1 |
| Telecentricity(° max) | <0.1 |
| I/O(mm) | 748±5 |
| Length(mm) | 401.5 |
| Mount | F-Mount/Other |
| Weight(kg) | 6.1 |
| Field of View(mm×mm) | |
| Line-2K(20.48mm) | 69.9mm |
| Line-4K(28.67mm) | 97.9mm |
| Line-8K(40.96mm) | 139.8mm |
| 35mm Format(36.0x24.0) | 122.9x81.9 |

BTL-0.23X-330-FF(LM)

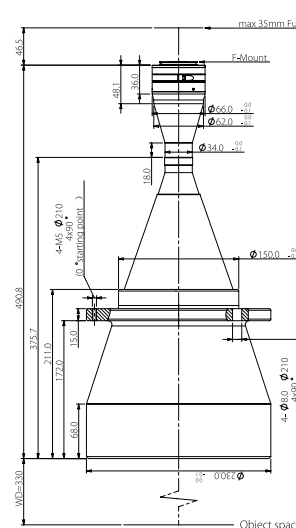

| | |
|------------------------|---------------|
| FOV(Φmm) | 190 |
| Mag.(x) | 0.230 |
| WD(mm) | 330±5 |
| Max Sensor Size(Φmm) | 44(35mm Full) |
| F/# | 10.3 |
| MTF30(lp/mm) | >85 |
| DoF(mm) | ±15.1@F20 |
| Distortion(% max) | <0.1 |
| Telecentricity(° max) | <0.1 |
| I/O(mm) | 867±5 |
| Length(mm) | 490.8 |
| Mount | F-Mount/Other |
| Weight(kg) | 11.4 |
| Field of View(mm×mm) | |
| Line-2K(20.48mm) | 89.0mm |
| Line-4K(28.67mm) | 124.7mm |
| Line-8K(40.96mm) | 178.1mm |
| 35mm Format(36.0x24.0) | 156.5x104.4 |

BTL-0.183X-410-FF(LM)

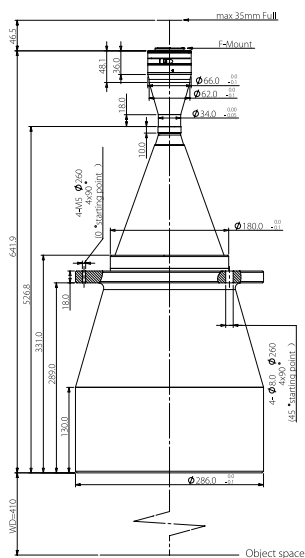

| | |
|------------------------|---------------|
| FOV(Φmm) | 240 |
| Mag.(x) | 0.183 |
| WD(mm) | 410±6 |
| Max Sensor Size(Φmm) | 44(35mm Full) |
| F/# | 10.3 |
| MTF30(lp/mm) | >85 |
| DoF(mm) | ±23.8@F20 |
| Distortion(% max) | <0.1 |
| Telecentricity(° max) | <0.1 |
| I/O(mm) | 1098±6 |
| Length(mm) | 641.9 |
| Mount | F-Mount/Other |
| Weight(kg) | 25.9 |
| Field of View(mm×mm) | |
| Line-2K(20.48mm) | 111.9mm |
| Line-4K(28.67mm) | 156.7mm |
| Line-8K(40.96mm) | 223.8mm |
| 35mm Format(36.0x24.0) | 196.7x131.2 |

BTL-0.147X-465-FF(LM)

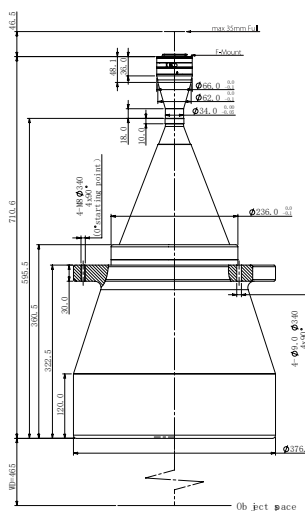

| | |
|------------------------|---------------|
| FOV(Φmm) | 300 |
| Mag.(x) | 0.147 |
| WD(mm) | 465±6 |
| Max Sensor Size(Φmm) | 44(35mm Full) |
| F/# | 10.3 |
| MTF30(lp/mm) | >85 |
| DoF(mm) | ±37@F20 |
| Distortion(% max) | <0.1 |
| Telecentricity(° max) | <0.1 |
| I/O(mm) | 1222±6 |
| Length(mm) | 710.6 |
| Mount | F-Mount/Other |
| Weight(kg) | 47.0 |
| Field of View(mm×mm) | |
| Line-2K(20.48mm) | 139.3mm |
| Line-4K(28.67mm) | 195.0mm |
| Line-8K(40.96mm) | 278.6mm |
| 35mm Format(36.0x24.0) | 244.9x163.3 |