

BTL SERIES

NEW



PRODUCT FEATURES

1. Optimized for 1/2.5"~1.1" C-Mount cameras;
2. Largest FOV from 26mm upto 300mm;
3. Excellent resolution for high pixel cameras;
4. Low distortion, good telecentricity, big aperture and big depth of field for high end application.

NAMING RULES

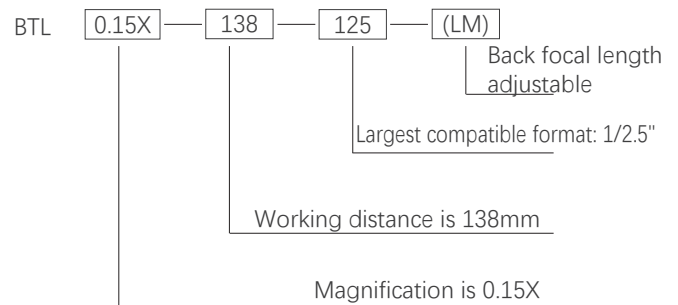

OVERVIEW

BTL Series Magnification Crosstab

Sensor Size FOV (mm) Mag X	1/2.5" BTL-125	1/2" BTL-12	1/1.8" BTL-118	2/3" BTL-23	1" BTL-H1	1.1" BTL-H1.1	4/3" BTL-H2	1.75" BTL-175	2" BTL-21	39mm BTL-71M	44mm BTL-FF	59mm BTL-16K	WD (mm)
26	0.277	0.308	0.346	0.438	0.638	0.708	0.923	1.115	/	/	/	/	73
36	0.2	0.222	0.25	0.317	0.46	0.511	0.67	0.806	0.917	1.083	/	/	110
42	0.171	0.19	0.214	0.271	0.395	0.438	0.571	0.69	0.786	0.929	1.048	/	118
48	0.15	0.167	0.188	0.238	0.346	0.383	0.5	0.604	0.688	0.813	0.92	/	128
56	0.129	0.143	0.161	0.204	0.296	0.329	0.429	0.518	0.589	0.696	0.785	/	138
64	0.113	0.125	0.14	0.178	0.258	0.287	0.375	0.453	0.516	0.609	0.688	/	189
72	0.1	0.111	0.125	0.158	0.231	0.256	0.333	0.403	0.458	0.542	0.611	/	178
80	0.09	0.1	0.113	0.142	0.206	0.23	0.3	0.363	0.41	0.488	0.55	/	228
90	0.08	0.089	0.1	0.127	0.184	0.204	0.267	0.322	0.367	0.433	0.489	0.656	208
100	0.072	0.08	0.09	0.114	0.166	0.184	0.24	0.29	0.33	0.39	0.44	/	258
120	0.06	0.067	0.075	0.095	0.138	0.153	0.2	0.242	0.275	0.325	0.367	/	280
150	0.048	0.053	0.06	0.076	0.11	0.123	0.16	0.193	0.22	0.26	0.293	0.393	300
190	0.038	0.042	0.047	0.06	0.087	0.097	0.126	0.153	0.174	0.205	0.23	0.311	330
240	0.03	0.033	0.038	0.048	0.069	0.077	0.1	0.121	0.138	0.163	0.183	0.246	410
300	0.024	0.027	0.03	0.038	0.055	0.061	0.08	0.097	0.11	0.13	0.147	0.197	465
Mount	C	C	C	C	C	C	C/F	F	F	F	F	M72	

BTL-23 SERIES

2/3"



Model No. ¹	Optical specs										Mechanical specs		
	FOV (Φmm)	Mag. (x)	WD (mm) ²	Max. Sensor Size (Φmm)	F/#	MTF30 (lp/mm)	DOF (mm) ³	Distortion (% max) ⁴	Telecentricity (° max) ⁵	I/O (mm) ⁶	Length (mm)	Mount	Weight (kg)
BTL-0.438X-73-23	26	0.438	73±1	11.4(2/3")	6	>130	±2.3@F11	<0.1	<0.1	208±1	117.9	C-Mount	0.3
BTL-0.317X-110-23	36	0.317	110±2	11.4(2/3")	5.4	>145	±4.3@F11	<0.1	<0.1	265±2	137.9	C-Mount	0.4
BTL-0.271X-118-23	42	0.271	118±3	11.4(2/3")	4.9	>185	±6.0@F11	<0.1	<0.1	259±3	123.4	C-Mount	0.4
BTL-0.238X-128-23	48	0.238	128±3	11.4(2/3")	5.4	>165	±7.7@F11	<0.1	<0.1	282±3	136.9	C-Mount	0.5
BTL-0.238X-138-23(LM)	48	0.238	138±3	11.4(2/3")	6.7	>130	±7.7@F11	<0.1	<0.1	278±3	122.0	C-Mount	0.5
BTL-0.204X-138-23(LM)	56	0.204	138±3	11.4(2/3")	4.9	>180	±10.5@F11	<0.1	<0.1	315±3	159.5	C-Mount	0.7
BTL-0.178X-189-23(LM)	64	0.178	189±3	11.4(2/3")	5.4	>145	±13.8@F11	<0.1	<0.1	355±3	148.0	C-Mount	0.8
BTL-0.158X-178-23(LM)	72	0.158	178±3	11.4(2/3")	4.9	>180	±17.6@F11	<0.1	<0.1	388±3	192.0	C-Mount	1
BTL-0.142X-228-23(LM)	80	0.142	228±4	11.4(2/3")	5.4	>150	±21.8@F11	<0.1	<0.1	427±4	181.9	C-Mount	1.5
BTL-0.127X-208-23(LM)	90	0.127	208±3	11.4(2/3")	4.9	>180	±27.2@F11	<0.1	<0.1	443±3	217.0	C-Mount	1.7
BTL-0.114X-258-23(LM)	100	0.114	258±4	11.4(2/3")	5.4	>170	±33.8@F11	<0.1	<0.1	516±4	240.4	C-Mount	3.1
BTL-0.095X-280-23(LM)	120	0.095	280±5	11.4(2/3")	4.9	>185	±48.7@F11	<0.1	<0.1	578±5	280.7	C-Mount	4.2
BTL-0.076X-300-23(LM)	150	0.076	300±5	11.4(2/3")	4.9	>185	±76.1@F11	<0.1	<0.1	642±5	324.0	C-Mount	5.7
BTL-0.06X-330-23(LM)	190	0.060	330±5	11.4(2/3")	4.9	>180	±122@F11	<0.1	<0.1	761±5	413.2	C-Mount	11
BTL-0.048X-410-23(LM)	240	0.048	410±6	11.4(2/3")	4.9	>180	±190@F11	<0.1	<0.1	992±6	564.3	C-Mount	25.5
BTL-0.038X-465-23(LM)	300	0.038	465±6	11.4(2/3")	4.9	>180	±304@F11	<0.1	<0.1	1116±6	633.0	C-Mount	46.6

1. The back focal length of model with (LM) is adjustable.

2. Working distance: distance between the front end of the mechanics and the object.
Set this distance within the nominal value for maximum resolution and minimum distortion.

3. At the borders of the field depth the image can be still used for measurement.

4. Percent deviation of the real image compared to an ideal, undistorted image:
maximum (guaranteed) values are listed.

5. Maximum slope of chief rays inside the lens: when converted to milliradians, it gives the maximum measurement error for any millimeter of object displacement.
Maximum (guaranteed) values are listed.

6. I/O: distance between the sensor(image) and the object.

BTL-0.438X-73-23

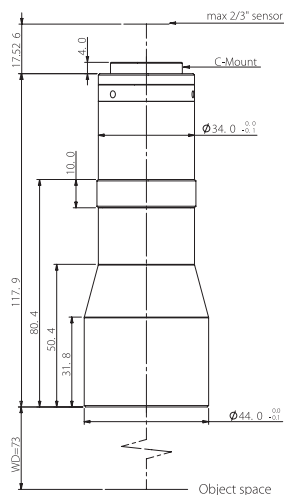

FOV(Φ mm)	26
Mag.(x)	0.438
WD(mm)	73 \pm 1
Max Sensor Size(Φ mm)	11.4(2/3")
F/#	6.0
MTF30(lp/mm)	>130
DoF(mm)	\pm 2.3@F11
Distortion(% max)	<0.1
Telecentricity($^{\circ}$ max)	<0.1
I/O(mm)	208 \pm 1
Length(mm)	117.9
Mount	C-Mount
Weight(kg)	0.3
Field of View(mm \times mm)	
2/3" ICX625/655(8.47 \times 7.1)	19.3 \times 16.2

BTL-0.317X-110-23

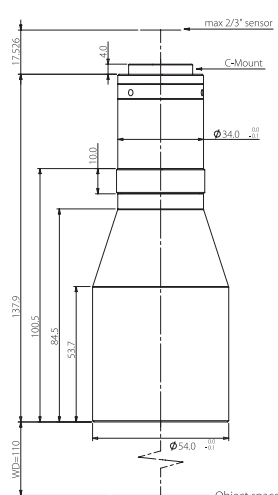

FOV(Φ mm)	36
Mag.(x)	0.317
WD(mm)	110 \pm 2
Max Sensor Size(Φ mm)	11.4(2/3")
F/#	5.4
MTF30(lp/mm)	>145
DoF(mm)	\pm 4.3@F11
Distortion(% max)	<0.1
Telecentricity($^{\circ}$ max)	<0.1
I/O(mm)	265 \pm 2
Length(mm)	137.9
Mount	C-Mount
Weight(kg)	0.4
Field of View(mm \times mm)	
2/3" ICX625/655(8.47 \times 7.1)	26.7 \times 22.4

BTL-0.271X-118-23

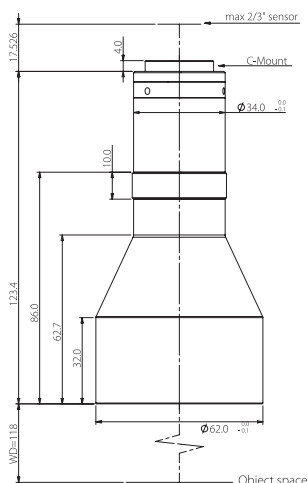

FOV(Φ mm)	42
Mag.(x)	0.271
WD(mm)	118 \pm 3
Max Sensor Size(Φ mm)	11.4(2/3")
F/#	4.9
MTF30(lp/mm)	>185
DoF(mm)	\pm 6.0@F11
Distortion(% max)	<0.1
Telecentricity($^{\circ}$ max)	<0.1
I/O(mm)	259 \pm 3
Length(mm)	123.4
Mount	C-Mount
Weight(kg)	0.4
Field of View(mm \times mm)	
2/3" ICX625/655(8.47 \times 7.1)	31.3 \times 26.2

BTL-0.238X-128-23

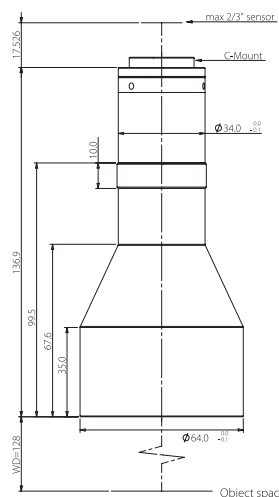

FOV(Φ mm)	48
Mag.(x)	0.238
WD(mm)	128 \pm 3
Max Sensor Size(Φ mm)	11.4(2/3")
F/#	5.4
MTF30(lp/mm)	>165
DoF(mm)	\pm 7.7@F11
Distortion(% max)	<0.1
Telecentricity($^{\circ}$ max)	<0.1
I/O(mm)	282 \pm 3
Length(mm)	136.9
Mount	C-Mount
Weight(kg)	0.5
Field of View(mm \times mm)	
2/3" ICX625/655(8.47 \times 7.1)	35.6 \times 29.8

BTL-0.238X-138-23(LM)

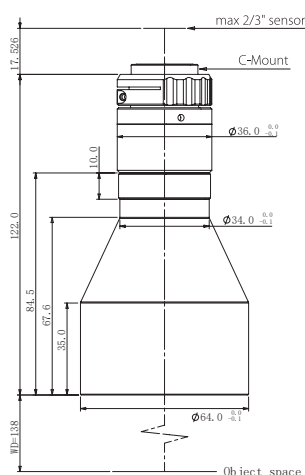

FOV(Φ mm)	48
Mag.(x)	0.238
WD(mm)	138 \pm 3
Max Sensor Size(Φ mm)	11.4(2/3")
F/#	6.7
MTF30(lp/mm)	>130
DoF(mm)	\pm 7.7@F11
Distortion(% max)	<0.1
Telecentricity($^{\circ}$ max)	<0.1
I/O(mm)	278 \pm 3
Length(mm)	122.0
Mount	C-Mount
Weight(kg)	0.5
Field of View(mm \times mm)	
2/3" ICX625/655(8.47 \times 7.1)	35.6 \times 29.8

BTL-0.204X-138-23(LM)

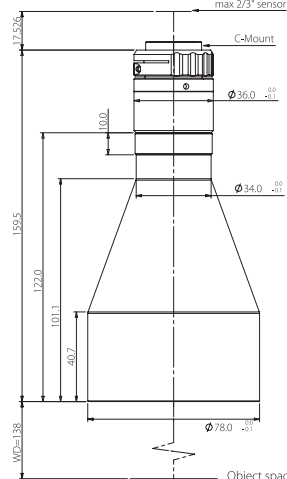

FOV(Φ mm)	56
Mag.(x)	0.204
WD(mm)	138 \pm 3
Max Sensor Size(Φ mm)	11.4(2/3")
F/#	4.9
MTF30(lp/mm)	>180
DoF(mm)	\pm 10.5@F11
Distortion(% max)	<0.1
Telecentricity($^{\circ}$ max)	<0.1
I/O(mm)	315 \pm 3
Length(mm)	159.5
Mount	C-Mount
Weight(kg)	0.7
Field of View(mm \times mm)	
2/3" ICX625/655(8.47 \times 7.1)	41.5 \times 34.8

BTL-0.178X-189-23(LM)

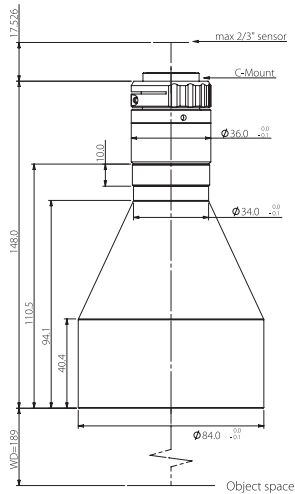

FOV(Φmm)	64
Mag.(x)	0.178
WD(mm)	189±3
Max Sensor Size(Φmm)	11.4(2/3")
F/#	5.4
MTF30(lp/mm)	>145
DoF(mm)	±13.8@F11
Distortion(% max)	<0.1
Telecentricity(° max)	<0.1
I/O(mm)	355±3
Length(mm)	148.0
Mount	C-Mount
Weight(kg)	0.8
Field of View(mm x mm)	
2/3" ICX625/655(8.47x7.1)	47.6x39.9

BTL-0.158X-178-23(LM)

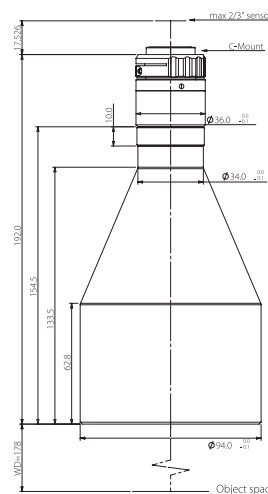

FOV(Φmm)	72
Mag.(x)	0.158
WD(mm)	178±3
Max Sensor Size(Φmm)	11.4(2/3")
F/#	4.9
MTF30(lp/mm)	>180
DoF(mm)	±17.6@F11
Distortion(% max)	<0.1
Telecentricity(° max)	<0.1
I/O(mm)	388±3
Length(mm)	192.0
Mount	C-Mount
Weight(kg)	1.0
Field of View(mm x mm)	
2/3" ICX625/655(8.47x7.1)	53.6x44.9

BTL-0.142X-228-23(LM)

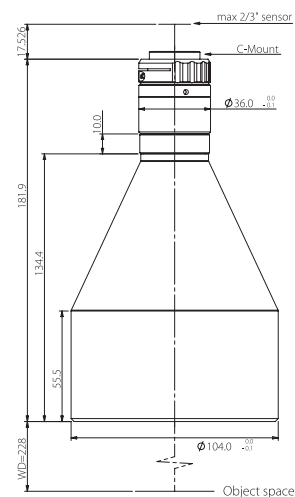

FOV(Φmm)	80
Mag.(x)	0.142
WD(mm)	228±4
Max Sensor Size(Φmm)	11.4(2/3")
F/#	5.4
MTF30(lp/mm)	>150
DoF(mm)	±21.8@F11
Distortion(% max)	<0.1
Telecentricity(° max)	<0.1
I/O(mm)	427±4
Length(mm)	181.9
Mount	C-Mount
Weight(kg)	1.5
Field of View(mm x mm)	
2/3" ICX625/655(8.47x7.1)	59.7x50.0

BTL-0.127X-208-23(LM)

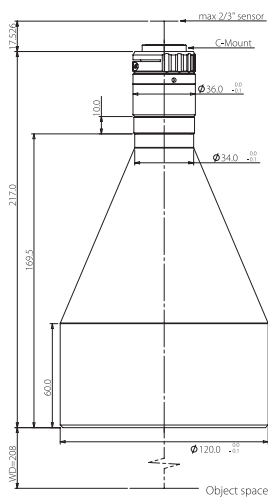

FOV(Φmm)	90
Mag.(x)	0.127
WD(mm)	208±3
Max Sensor Size(Φmm)	11.4(2/3")
F/#	4.9
MTF30(lp/mm)	>180
DoF(mm)	±27.2@F11
Distortion(% max)	<0.1
Telecentricity(° max)	<0.1
I/O(mm)	443±3
Length(mm)	217.0
Mount	C-Mount
Weight(kg)	1.7
Field of View(mm x mm)	
2/3" ICX625/655(8.47x7.1)	66.7x55.9

BTL-0.114X-258-23(LM)

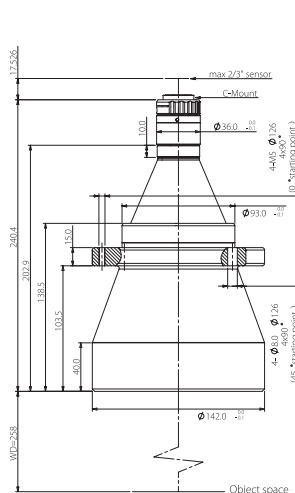

FOV(Φmm)	100
Mag.(x)	0.114
WD(mm)	258±4
Max Sensor Size(Φmm)	11.4(2/3")
F/#	5.4
MTF30(lp/mm)	>170
DoF(mm)	±33.8@F11
Distortion(% max)	<0.1
Telecentricity(° max)	<0.1
I/O(mm)	516±4
Length(mm)	240
Mount	C-Mount
Weight(kg)	3.1
Field of View(mm x mm)	
2/3" ICX625/655(8.47x7.1)	74.3x62.3

BTL-0.095X-280-23(LM)

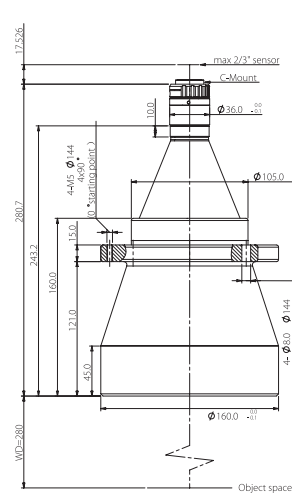

FOV(Φmm)	120
Mag.(x)	0.095
WD(mm)	280±5
Max Sensor Size(Φmm)	11.4(2/3")
F/#	4.9
MTF30(lp/mm)	>185
DoF(mm)	±48.7@F11
Distortion(% max)	<0.1
Telecentricity(° max)	<0.1
I/O(mm)	578±5
Length(mm)	280.7
Mount	C-Mount
Weight(kg)	4.2
Field of View(mm x mm)	
2/3" ICX625/655(8.47x7.1)	89.2x74.7

BTL-0.076X-300-23(LM)

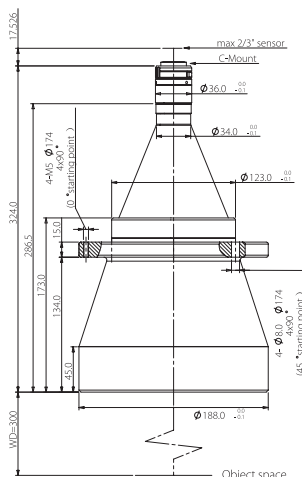

FOV(Φmm)	150
Mag.(x)	0.076
WD(mm)	300±5
Max Sensor Size(Φmm)	11.4(2/3")
F/#	4.9
MTF30(lp/mm)	>185
DoF(mm)	±76.1@F11
Distortion(% max)	<0.1
Telecentricity(° max)	<0.1
I/O(mm)	642.5±5
Length(mm)	324.0
Mount	C-Mount
Weight(kg)	5.7
Field of View(mm xmm)	
2/3" ICX625/655(8.47x7.1)	111.5x93.4

BTL-0.06X-330-23(LM)

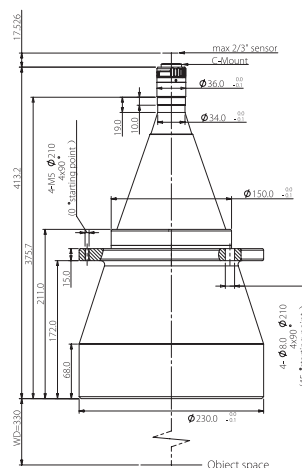

FOV(Φmm)	190
Mag.(x)	0.060
WD(mm)	330±5
Max Sensor Size(Φmm)	11.4(2/3")
F/#	4.9
MTF30(lp/mm)	>180
DoF(mm)	±122@F11
Distortion(% max)	<0.1
Telecentricity(° max)	<0.1
I/O(mm)	761±5
Length(mm)	413.2
Mount	C-Mount
Weight(kg)	11.0
Field of View(mm xmm)	
2/3" ICX625/655(8.47x7.1)	141.2x118.3

BTL-0.048X-410-23(LM)

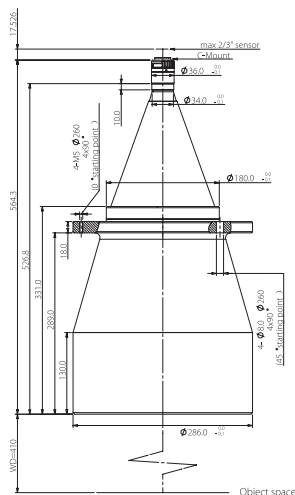

FOV(Φmm)	240
Mag.(x)	0.048
WD(mm)	410±6
Max Sensor Size(Φmm)	11.4(2/3")
F/#	4.9
MTF30(lp/mm)	>180
DoF(mm)	±190@F11
Distortion(% max)	<0.1
Telecentricity(° max)	<0.1
I/O(mm)	992±6
Length(mm)	564.3
Mount	C-Mount
Weight(kg)	25.5
Field of View(mm xmm)	
2/3" ICX625/655(8.47x7.1)	176.5x147.9

BTL-0.038X-465-23(LM)

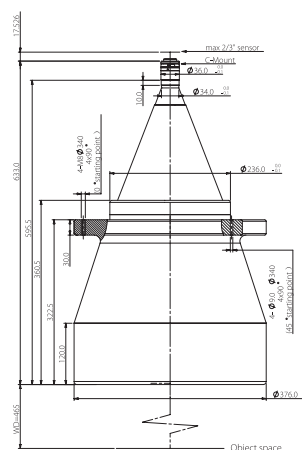

FOV(Φmm)	300
Mag.(x)	0.038
WD(mm)	465±6
Max Sensor Size(Φmm)	11.4(2/3")
F/#	4.9
MTF30(lp/mm)	>180
DoF(mm)	±304@F11
Distortion(% max)	<0.1
Telecentricity(° max)	<0.1
I/O(mm)	1116±6
Length(mm)	633.0
Mount	C-Mount
Weight(kg)	46.6
Field of View(mm xmm)	
2/3" ICX625/655(8.47x7.1)	222.9x186.8