

BTL SERIES

NEW



PRODUCT FEATURES

1. Optimized for 1/2.5"~1.1" C-Mount cameras;
2. Largest FOV from 26mm upto 300mm;
3. Excellent resolution for high pixel cameras;
4. Low distortion, good telecentricity, big aperture and big depth of field for high end application.

NAMING RULES

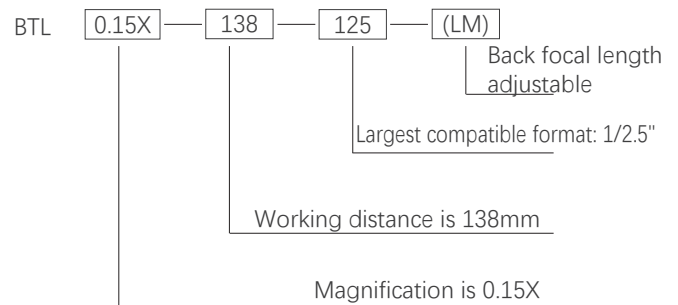

OVERVIEW

BTL Series Magnification Crosstab

Sensor Size FOV (mm) Mag X	1/2.5" BTL-125	1/2" BTL-12	1/1.8" BTL-118	2/3" BTL-23	1" BTL-H1	1.1" BTL-H1.1	4/3" BTL-H2	1.75" BTL-175	2" BTL-21	39mm BTL-71M	44mm BTL-FF	59mm BTL-16K	WD (mm)
26	0.277	0.308	0.346	0.438	0.638	0.708	0.923	1.115	/	/	/	/	73
36	0.2	0.222	0.25	0.317	0.46	0.511	0.67	0.806	0.917	1.083	/	/	110
42	0.171	0.19	0.214	0.271	0.395	0.438	0.571	0.69	0.786	0.929	1.048	/	118
48	0.15	0.167	0.188	0.238	0.346	0.383	0.5	0.604	0.688	0.813	0.92	/	128
56	0.129	0.143	0.161	0.204	0.296	0.329	0.429	0.518	0.589	0.696	0.785	/	138
64	0.113	0.125	0.14	0.178	0.258	0.287	0.375	0.453	0.516	0.609	0.688	/	189
72	0.1	0.111	0.125	0.158	0.231	0.256	0.333	0.403	0.458	0.542	0.611	/	178
80	0.09	0.1	0.113	0.142	0.206	0.23	0.3	0.363	0.41	0.488	0.55	/	228
90	0.08	0.089	0.1	0.127	0.184	0.204	0.267	0.322	0.367	0.433	0.489	0.656	208
100	0.072	0.08	0.09	0.114	0.166	0.184	0.24	0.29	0.33	0.39	0.44	/	258
120	0.06	0.067	0.075	0.095	0.138	0.153	0.2	0.242	0.275	0.325	0.367	/	280
150	0.048	0.053	0.06	0.076	0.11	0.123	0.16	0.193	0.22	0.26	0.293	0.393	300
190	0.038	0.042	0.047	0.06	0.087	0.097	0.126	0.153	0.174	0.205	0.23	0.311	330
240	0.03	0.033	0.038	0.048	0.069	0.077	0.1	0.121	0.138	0.163	0.183	0.246	410
300	0.024	0.027	0.03	0.038	0.055	0.061	0.08	0.097	0.11	0.13	0.147	0.197	465
Mount	C	C	C	C	C	C	C/F	F	F	F	F	M72	

BTL-21 SERIES

2"



Model No. ¹	Optical specs										Mechanical specs		
	FOV (Φmm)	Mag. (x)	WD (mm) ²	Max. Sensor Size (Φmm)	F/#	MTF30 (lp/mm)	DOF (mm) ³	Distortion (% max) ⁴	Telecentricity (° max) ⁵	I/O (mm) ⁶	Length (mm)	Mount	Weight (kg)
BTL-0.917X-110-21(LM)	36	0.917	110±2	33(2")	15.5	>50	±0.9@F20	<0.1	<0.1	347±2	190.5	F or other	0.9
BTL-0.786X-118-21(LM)	42	0.786	118±3	33(2")	12.9	>65	±1.2@F20	<0.1	<0.1	341±3	176	F or other	0.9
BTL-0.688X-128-21(LM)	48	0.688	128±3	33(2")	12.9	>60	±1.7@F20	<0.1	<0.1	364±3	189.5	F or other	0.9
BTL-0.688X-138-21(LM)	48	0.688	138±3	33(2")	19.4	>45	±1.7@F20	<0.1	<0.1	359±3	174.5	F or other	0.9
BTL-0.589X-138-21(LM)	56	0.589	138±3	33(2")	11.1	>75	±2.3@F20	<0.1	<0.1	397±3	212	F or other	1.2
BTL-0.516X-189-21(LM)	64	0.516	189±3	33(2")	19.4	>45	±3.0@F20	<0.1	<0.1	436±3	200.5	F or other	1.3
BTL-0.458X-178-21(LM)	72	0.458	178±3	33(2")	9.7	>90	±3.8@F20	<0.1	<0.1	469±3	244.5	F or other	1.5
BTL-0.41X-228-21(LM)	80	0.41	228±4	33(2")	19.4	>45	±4.7@F20	<0.1	<0.1	509±4	234.4	F or other	2
BTL-0.367X-208-21(LM)	90	0.367	208±3	33(2")	8.6	>100	±4.7@F16	<0.1	<0.1	524±3	269.5	F or other	2.1
BTL-0.33X-258-21(LM)	100	0.33	258±4	33(2")	12.9	>60	±7.3@F20	<0.1	<0.1	597±4	292.8	F or other	3.5
BTL-0.275X-280-21(LM)	120	0.275	280±5	33(2")	11.1	>80	±10.5@F20	<0.1	<0.1	660±5	333.2	F or other	4.7
BTL-0.22X-300-21(LM)	150	0.22	300±5	33(2")	11.1	>80	±16.5@F20	<0.1	<0.1	723±5	376.4	F or other	6.1
BTL-0.174X-330-21(LM)	190	0.174	330±5	33(2")	7.8	>115	±21.1@F16	<0.1	<0.1	842±5	465.7	F or other	11.5
BTL-0.138X-410-21(LM)	240	0.138	410±6	33(2")	7.8	>115	±33.6@F16	<0.1	<0.1	1073±6	616.8	F or other	26
BTL-0.11X-465-21(LM)	300	0.11	465±6	33(2")	7.8	>115	±52.8@F16	<0.1	<0.1	1197±6	685.5	F or other	47

1. The back focal length of model with (LM) is adjustable.

2. Working distance: distance between the front end of the mechanics and the object.
Set this distance within the nominal value for maximum resolution and minimum distortion.

3. At the borders of the field depth the image can be still used for measurement.

4. Percent deviation of the real image compared to an ideal, undistorted image:
maximum (guaranteed) values are listed.

5. Maximum slope of chief rays inside the lens: when converted to milliradians, it gives the maximum measurement error for any millimeter of object displacement.
Maximum (guaranteed) values are listed.

6. I/O: distance between the sensor(image) and the object.

BTL-0.917X-110-21(LM)

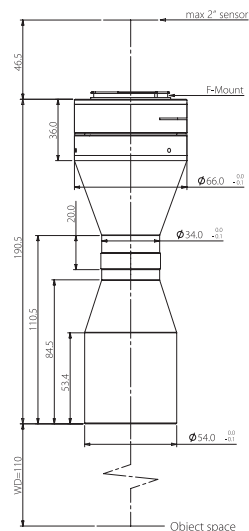

FOV(Φmm)	36
Mag.(x)	0.917
WD(mm)	110±2
Max Sensor Size(Φmm)	33(2")
F/#	15.5
MTF30(lp/mm)	>50
DoF(mm)	±0.9@F20
Distortion(% max)	<0.1
Telecentricity(° max)	<0.1
I/O(mm)	347±2
Length(mm)	190.5
Mount	F-Mount/Other
Weight(kg)	0.9
Field of View(mmxmm)	
2" KAI-16050(26.93x17.95)	29.4x19.6
2" PYTHON 25K(23.04x23.04)	25.1x25.1

BTL-0.786X-118-21(LM)

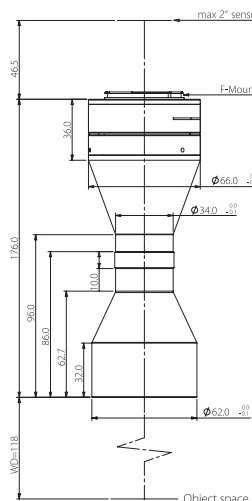

FOV(Φmm)	42
Mag.(x)	0.786
WD(mm)	118±3
Max Sensor Size(Φmm)	33(2")
F/#	12.9
MTF30(lp/mm)	>65
DoF(mm)	±1.2@F20
Distortion(% max)	<0.1
Telecentricity(° max)	<0.1
I/O(mm)	341±3
Length(mm)	176.0
Mount	F-Mount/Other
Weight(kg)	0.9
Field of View(mmxmm)	
2" KAI-16050(26.93x17.95)	34.3x22.8
2" PYTHON 25K(23.04x23.04)	29.3x29.3

BTL-0.688X-128-21(LM)

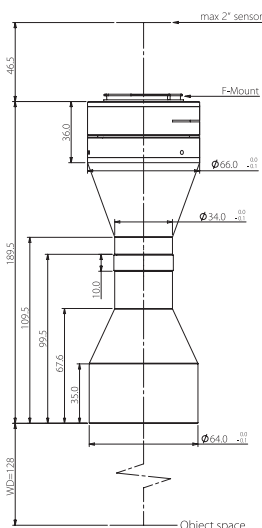

FOV(Φmm)	48
Mag.(x)	0.688
WD(mm)	128±3
Max Sensor Size(Φmm)	33(2")
F/#	12.9
MTF30(lp/mm)	>60
DoF(mm)	±1.7@F20
Distortion(% max)	<0.1
Telecentricity(° max)	<0.1
I/O(mm)	364±3
Length(mm)	189.5
Mount	F-Mount/Other
Weight(kg)	0.9
Field of View(mmxmm)	
2" KAI-16050(26.93x17.95)	39.1x26.1
2" PYTHON 25K(23.04x23.04)	33.5x33.5

BTL-0.688X-138-21(LM)

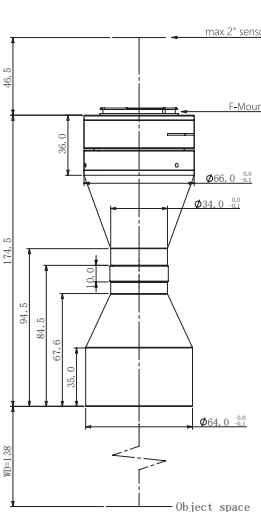

FOV(Φmm)	48
Mag.(x)	0.688
WD(mm)	138±3
Max Sensor Size(Φmm)	33(2")
F/#	19.4
MTF30(lp/mm)	>45
DoF(mm)	±1.7@F20
Distortion(% max)	<0.1
Telecentricity(° max)	<0.1
I/O(mm)	359±3
Length(mm)	174.5
Mount	F-Mount/Other
Weight(kg)	0.9
Field of View(mmxmm)	
2" KAI-16050(26.93x17.95)	39.1x26.1
2" PYTHON 25K(23.04x23.04)	33.5x33.5

BTL-0.589X-138-21(LM)

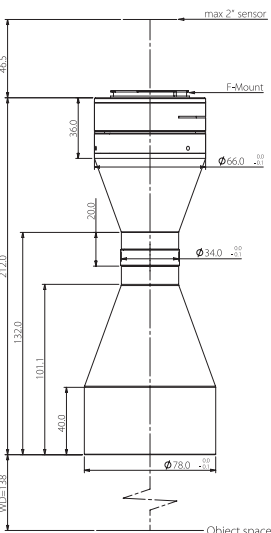

FOV(Φmm)	56
Mag.(x)	0.589
WD(mm)	138±3
Max Sensor Size(Φmm)	33(2")
F/#	11.1
MTF30(lp/mm)	>75
DoF(mm)	±2.3@F20
Distortion(% max)	<0.1
Telecentricity(° max)	<0.1
I/O(mm)	397±3
Length(mm)	212.0
Mount	F-Mount/Other
Weight(kg)	1.2
Field of View(mmxmm)	
2" KAI-16050(26.93x17.95)	45.7x30.5
2" PYTHON 25K(23.04x23.04)	39.1x39.1

BTL-0.516X-189-21(LM)

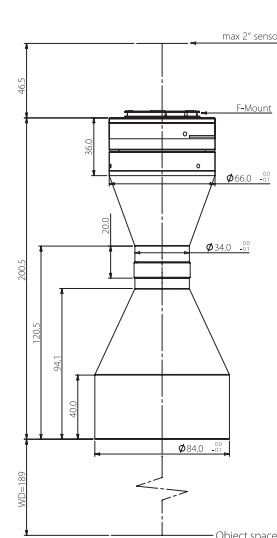

FOV(Φmm)	64
Mag.(x)	0.516
WD(mm)	189±3
Max Sensor Size(Φmm)	33(2")
F/#	19.4
MTF30(lp/mm)	>45
DoF(mm)	±3.0@F20
Distortion(% max)	<0.1
Telecentricity(° max)	<0.1
I/O(mm)	436±3
Length(mm)	200.5
Mount	F-Mount/Other
Weight(kg)	1.3
Field of View(mmxmm)	
2" KAI-16050(26.93x17.95)	52.2x34.8
2" PYTHON 25K(23.04x23.04)	44.7x44.7

BTL-0.458X-178-21(LM)

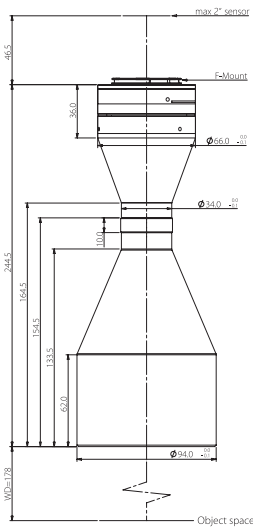

FOV(Φmm)	72
Mag.(x)	0.458
WD(mm)	178±3
Max Sensor Size(Φmm)	33(2")
F/#	9.7
MTF30(lp/mm)	>90
DoF(mm)	±3.8@F20
Distortion(% max)	<0.1
Telecentricity(° max)	<0.1
I/O(mm)	469±3
Length(mm)	244.5
Mount	F-Mount/Other
Weight(kg)	1.5
Field of View(mm x mm)	
2" KAI-16050(26.93x17.95)	58.8x39.2
2" PYTHON 25K(23.04x23.04)	50.3x50.3

BTL-0.41X-228-21(LM)

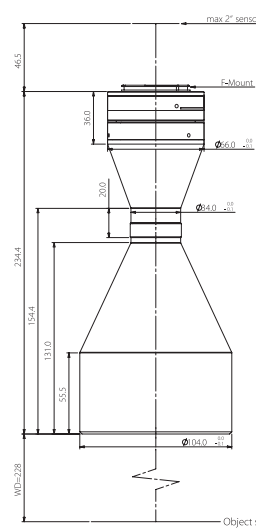

FOV(Φmm)	80
Mag.(x)	0.410
WD(mm)	228±4
Max Sensor Size(Φmm)	33(2")
F/#	19.4
MTF30(lp/mm)	>45
DoF(mm)	±4.7@F20
Distortion(% max)	<0.1
Telecentricity(° max)	<0.1
I/O(mm)	509±4
Length(mm)	234.4
Mount	F-Mount/Other
Weight(kg)	2.0
Field of View(mm x mm)	
2" KAI-16050(26.93x17.95)	65.7x43.8
2" PYTHON 25K(23.04x23.04)	56.2x56.2

BTL-0.367X-208-21(LM)

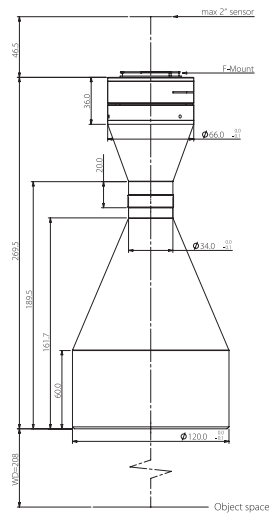

FOV(Φmm)	90
Mag.(x)	0.367
WD(mm)	208±3
Max Sensor Size(Φmm)	33(2")
F/#	8.6
MTF30(lp/mm)	>100
DoF(mm)	±4.7@F16
Distortion(% max)	<0.1
Telecentricity(° max)	<0.1
I/O(mm)	524±3
Length(mm)	269.5
Mount	F-Mount/Other
Weight(kg)	2.1
Field of View(mm x mm)	
2" KAI-16050(26.93x17.95)	73.4x48.9
2" PYTHON 25K(23.04x23.04)	62.8x62.8

BTL-0.33X-258-21(LM)

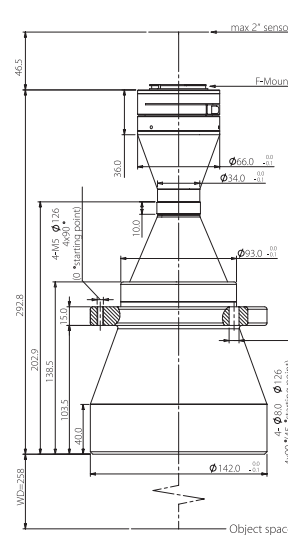

FOV(Φmm)	100
Mag.(x)	0.330
WD(mm)	258±4
Max Sensor Size(Φmm)	33(2")
F/#	12.9
MTF30(lp/mm)	>60
DoF(mm)	±7.3@F20
Distortion(% max)	<0.1
Telecentricity(° max)	<0.1
I/O(mm)	597±4
Length(mm)	292.8
Mount	F-Mount/Other
Weight(kg)	3.5
Field of View(mm x mm)	
2" KAI-16050(26.93x17.95)	81.6x54.4
2" PYTHON 25K(23.04x23.04)	69.8x69.8

BTL-0.275X-280-21(LM)

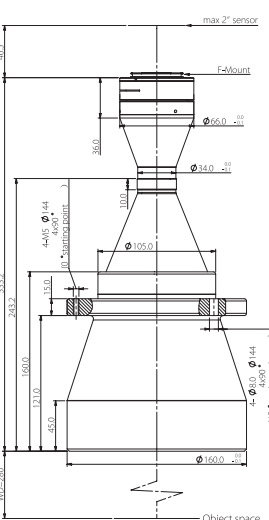

FOV(Φmm)	120
Mag.(x)	0.275
WD(mm)	280±5
Max Sensor Size(Φmm)	33(2")
F/#	11.1
MTF30(lp/mm)	>80
DoF(mm)	±10.5@F20
Distortion(% max)	<0.1
Telecentricity(° max)	<0.1
I/O(mm)	660±5
Length(mm)	333.2
Mount	F-Mount/Other
Weight(kg)	4.7
Field of View(mm x mm)	
2" KAI-16050(26.93x17.95)	97.9x65.3
2" PYTHON 25K(23.04x23.04)	83.8x83.8

BTL-0.22X-300-21(LM)

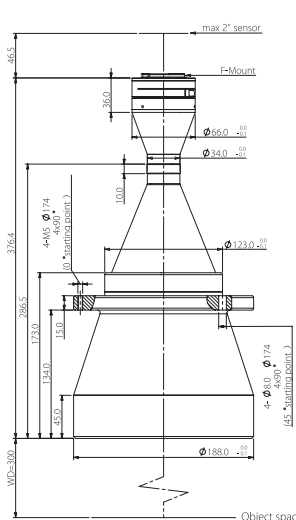

FOV(Φmm)	150
Mag.(x)	0.220
WD(mm)	300±5
Max Sensor Size(Φmm)	33(2")
F/#	11.1
MTF30(lp/mm)	>80
DoF(mm)	±16.5@F20
Distortion(% max)	<0.1
Telecentricity(° max)	<0.1
I/O(mm)	723±5
Length(mm)	376.4
Mount	F-Mount/Other
Weight(kg)	6.1
Field of View(mm x mm)	
2" KAI-16050(26.93x17.95)	122.4x81.6
2" PYTHON 25K(23.04x23.04)	104.7x104.7

BTL-0.174X-330-21(LM)

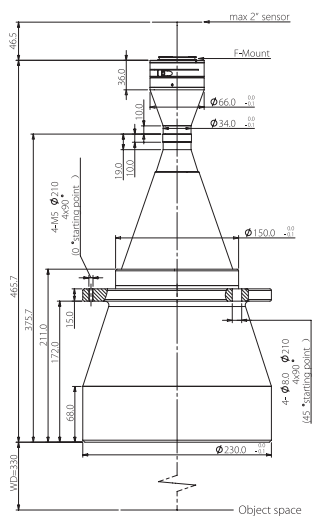

FOV(Φmm)	190
Mag.(x)	0.174
WD(mm)	330±5
Max Sensor Size(Φmm)	33(2")
F/#	7.8
MTF30(lp/mm)	>115
DoF(mm)	±21.1@F16
Distortion(% max)	<0.1
Telecentricity(° max)	<0.1
I/O(mm)	842±5
Length(mm)	465.7
Mount	F-Mount/Other
Weight(kg)	11.5
Field of View(mmxmm)	
2" KAI-16050(26.93x17.95)	154.8x103.2
2" PYTHON 25K(23.04x23.04)	132.4x132.4

BTL-0.138X-410-21(LM)

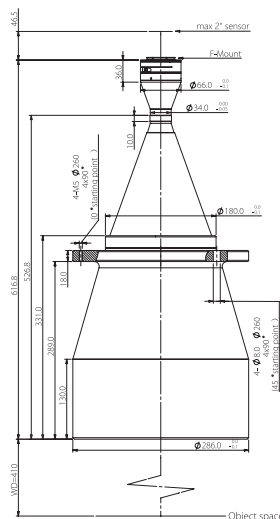

FOV(Φmm)	240
Mag.(x)	0.138
WD(mm)	410±6
Max Sensor Size(Φmm)	33(2")
F/#	7.8
MTF30(lp/mm)	>115
DoF(mm)	±33.6@F16
Distortion(% max)	<0.1
Telecentricity(° max)	<0.1
I/O(mm)	1073±6
Length(mm)	616.8
Mount	F-Mount/Other
Weight(kg)	26.0
Field of View(mmxmm)	
2" KAI-16050(26.93x17.95)	195.1x130.1
2" PYTHON 25K(23.04x23.04)	167.0x167.0

BTL-0.11X-465-21(LM)

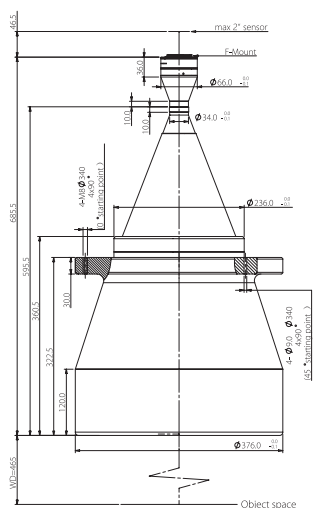

FOV(Φmm)	300
Mag.(x)	0.110
WD(mm)	465±6
Max Sensor Size(Φmm)	33(2")
F/#	7.8
MTF30(lp/mm)	>115
DoF(mm)	±52.8@F16
Distortion(% max)	<0.1
Telecentricity(° max)	<0.1
I/O(mm)	1197±6
Length(mm)	685.5
Mount	F-Mount/Other
Weight(kg)	47.0
Field of View(mmxmm)	
2" KAI-16050(26.93x17.95)	244.8x163.2
2" PYTHON 25K(23.04x23.04)	209.5x209.5