

BTL SERIES

NEW



PRODUCT FEATURES

1. Optimized for 1/2.5"~1.1" C-Mount cameras;
2. Largest FOV from 26mm upto 300mm;
3. Excellent resolution for high pixel cameras;
4. Low distortion, good telecentricity, big aperture and big depth of field for high end application.

NAMING RULES

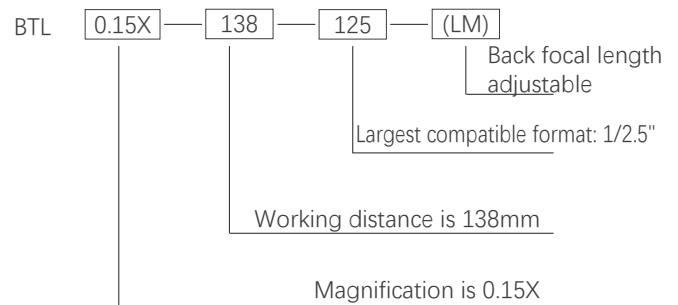

OVERVIEW

BTL Series Magnification Crosstab

Sensor Size FOV (mm) Mag X	1/2.5" BTL-125	1/2" BTL-12	1/1.8" BTL-118	2/3" BTL-23	1" BTL-H1	1.1" BTL-H1.1	4/3" BTL-H2	1.75" BTL-175	2" BTL-21	39mm BTL-71M	44mm BTL-FF	59mm BTL-16K	WD (mm)
26	0.277	0.308	0.346	0.438	0.638	0.708	0.923	1.115	/	/	/	/	73
36	0.2	0.222	0.25	0.317	0.46	0.511	0.67	0.806	0.917	1.083	/	/	110
42	0.171	0.19	0.214	0.271	0.395	0.438	0.571	0.69	0.786	0.929	1.048	/	118
48	0.15	0.167	0.188	0.238	0.346	0.383	0.5	0.604	0.688	0.813	0.92	/	128
56	0.129	0.143	0.161	0.204	0.296	0.329	0.429	0.518	0.589	0.696	0.785	/	138
64	0.113	0.125	0.14	0.178	0.258	0.287	0.375	0.453	0.516	0.609	0.688	/	189
72	0.1	0.111	0.125	0.158	0.231	0.256	0.333	0.403	0.458	0.542	0.611	/	178
80	0.09	0.1	0.113	0.142	0.206	0.23	0.3	0.363	0.41	0.488	0.55	/	228
90	0.08	0.089	0.1	0.127	0.184	0.204	0.267	0.322	0.367	0.433	0.489	0.656	208
100	0.072	0.08	0.09	0.114	0.166	0.184	0.24	0.29	0.33	0.39	0.44	/	258
120	0.06	0.067	0.075	0.095	0.138	0.153	0.2	0.242	0.275	0.325	0.367	/	280
150	0.048	0.053	0.06	0.076	0.11	0.123	0.16	0.193	0.22	0.26	0.293	0.393	300
190	0.038	0.042	0.047	0.06	0.087	0.097	0.126	0.153	0.174	0.205	0.23	0.311	330
240	0.03	0.033	0.038	0.048	0.069	0.077	0.1	0.121	0.138	0.163	0.183	0.246	410
300	0.024	0.027	0.03	0.038	0.055	0.061	0.08	0.097	0.11	0.13	0.147	0.197	465
Mount	C	C	C	C	C	C	C/F	F	F	F	F	M72	

BTL-125 SERIES

1/2.5"



Model No. ¹	Optical specs										Mechanical specs		
	FOV (Φmm)	Mag. (x)	WD (mm) ²	Max. Sensor Size (Φmm)	F/#	MTF30 (lp/mm)	DOF (mm) ³	Distortion (% max) ⁴	Telecentricity (° max) ⁵	I/O (mm) ⁶	Length (mm)	Mount	Weight (kg)
BTL-0.277X-73-125	26	0.277	73±1	7.2(1/2.5")	4.2	>190	±5.7@F11	<0.1	<0.1	194±1	103.4	C-Mount	0.3
BTL-0.2X-110-125	36	0.2	110±2	7.2(1/2.5")	4.2	>190	±11.0@F11	<0.1	<0.1	251±2	123.5	C-Mount	0.4
BTL-0.171X-118-125	42	0.171	118±3	7.2(1/2.5")	4.2	>200	±15.0@F11	<0.1	<0.1	245±3	108.9	C-Mount	0.4
BTL-0.15X-128-125	48	0.15	128±3	7.2(1/2.5")	4.2	>190	±19.5@F11	<0.1	<0.1	268±3	122.4	C-Mount	0.4
BTL-0.15X-138-125(LM)	48	0.15	138±3	7.2(1/2.5")	4.2	>190	±19.5@F11	<0.1	<0.1	263±3	107.5	C-Mount	0.4
BTL-0.129X-138-125(LM)	56	0.129	138±3	7.2(1/2.5")	4.2	>200	±26.4@F11	<0.1	<0.1	301±3	145	C-Mount	0.7
BTL-0.113X-189-125(LM)	64	0.113	189±3	7.2(1/2.5")	4.2	>190	±34.4@F11	<0.1	<0.1	340±3	133.5	C-Mount	0.8
BTL-0.1X-178-125(LM)	72	0.1	178±3	7.2(1/2.5")	4.2	>195	±44@F11	<0.1	<0.1	373±3	177.5	C-Mount	1
BTL-0.09X-228-125(LM)	80	0.09	228±4	7.2(1/2.5")	4.2	>190	±54.3@F11	<0.1	<0.1	413±4	167.4	C-Mount	1.5
BTL-0.08X-208-125(LM)	90	0.08	208±3	7.2(1/2.5")	4.2	>200	±68.7@F11	<0.1	<0.1	428±3	202.5	C-Mount	1.7
BTL-0.072X-258-125(LM)	100	0.072	258±4	7.2(1/2.5")	4.2	>210	±84.8@F11	<0.1	<0.1	501±4	225.9	C-Mount	3
BTL-0.06X-280-125(LM)	120	0.06	280±5	7.2(1/2.5")	4.2	>210	±122@F11	<0.1	<0.1	564±5	266.2	C-Mount	4.2
BTL-0.048X-300-125(LM)	150	0.048	300±5	7.2(1/2.5")	4.2	>210	±190@F11	<0.1	<0.1	627±5	309.5	C-Mount	5.7
BTL-0.038X-330-125(LM)	190	0.038	330±5	7.2(1/2.5")	4.2	>205	±304@F11	<0.1	<0.1	746±5	398.8	C-Mount	11
BTL-0.03X-410-125(LM)	240	0.03	410±6	7.2(1/2.5")	4.2	>210	±488@F11	<0.1	<0.1	977±6	549.9	C-Mount	25.5
BTL-0.024X-465-125(LM)	300	0.024	465±6	7.2(1/2.5")	4.2	>205	±763@F11	<0.1	<0.1	1101±6	618.5	C-Mount	46.5

1. The back focal length of model with (LM) is adjustable.

2. Working distance: distance between the front end of the mechanics and the object.
Set this distance within the nominal value for maximum resolution and minimum distortion.

3. At the borders of the field depth the image can be still used for measurement.

4. Percent deviation of the real image compared to an ideal, undistorted image:
maximum (guaranteed) values are listed.

5. Maximum slope of chief rays inside the lens: when converted to milliradians, it gives the maximum measurement error for any millimeter of object displacement.
Maximum (guaranteed) values are listed.

6. I/O: distance between the sensor(image) and the object.

BTL-0.277X-73-125

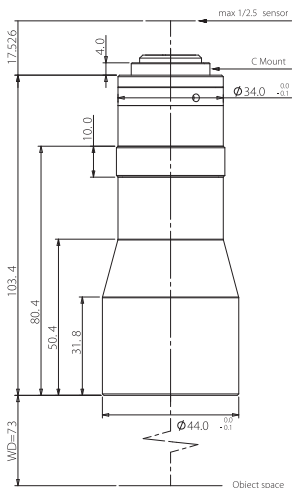

FOV(Φmm)	26
Mag.(x)	0.277
WD(mm)	73±1
Max Sensor Size(Φmm)	7.2(1/2.5")
F/#	4.2
MTF30(lp/mm)	>190
DoF(mm)	±5.7@F11
Distortion(% max)	<0.1
Telecentricity(° max)	<0.1
I/O(mm)	194±1
Length(mm)	103.4
Mount	C-Mount
Weight(kg)	0.3
Field of View(mm×mm)	1/2.5" 9P001/31(5.7x4.28) 20.6x15.5

BTL-0.2X-110-125

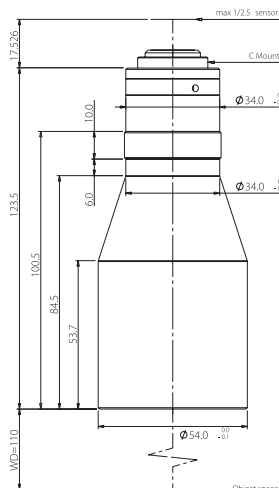

FOV(Φmm)	36
Mag.(x)	0.200
WD(mm)	110±2
Max Sensor Size(Φmm)	7.2(1/2.5")
F/#	4.2
MTF30(lp/mm)	>190
DoF(mm)	±11.0@F11
Distortion(% max)	<0.1
Telecentricity(° max)	<0.1
I/O(mm)	251±2
Length(mm)	123.5
Mount	C-Mount
Weight(kg)	0.4
Field of View(mm×mm)	1/2.5" 9P001/31(5.7x4.28) 28.5x21.4

BTL-0.171X-118-125

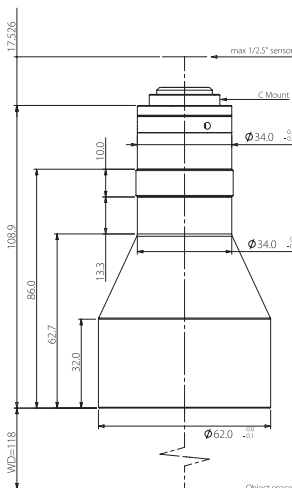

FOV(Φmm)	42
Mag.(x)	0.171
WD(mm)	118±3
Max Sensor Size(Φmm)	7.2(1/2.5")
F/#	4.2
MTF30(lp/mm)	>200
DoF(mm)	±15.0@F11
Distortion(% max)	<0.1
Telecentricity(° max)	<0.1
I/O(mm)	245±3
Length(mm)	108.9
Mount	C-Mount
Weight(kg)	0.4
Field of View(mm×mm)	1/2.5" 9P001/31(5.7x4.28) 33.3x25.0

BTL-0.15X128-125

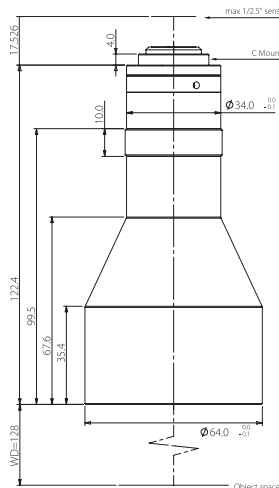

FOV(Φmm)	48
Mag.(x)	0.150
WD(mm)	128±3
Max Sensor Size(Φmm)	7.2(1/2.5")
F/#	4.2
MTF30(lp/mm)	>190
DoF(mm)	±19.5@F11
Distortion(% max)	<0.1
Telecentricity(° max)	<0.1
I/O(mm)	268±3
Length(mm)	122.4
Mount	C-Mount
Weight(kg)	0.4
Field of View(mm×mm)	1/2.5" 9P001/31(5.7x4.28) 38.0x28.5

BTL-0.15X-138-125(LM)

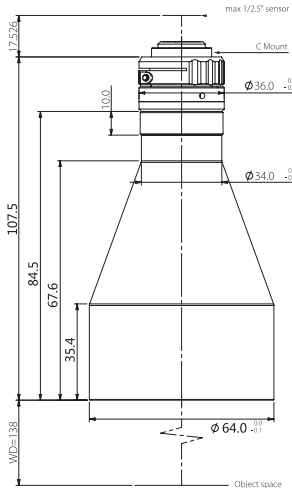

FOV(Φmm)	48
Mag.(x)	0.150
WD(mm)	138±3
Max Sensor Size(Φmm)	7.2(1/2.5")
F/#	4.2
MTF30(lp/mm)	>190
DoF(mm)	±19.5@F11
Distortion(% max)	<0.1
Telecentricity(° max)	<0.1
I/O(mm)	263±3
Length(mm)	107.5
Mount	C-Mount
Weight(kg)	0.4
Field of View(mm×mm)	1/2.5" 9P001/31(5.7x4.28) 38.0x28.5

BTL-0.129X-138-125(LM)

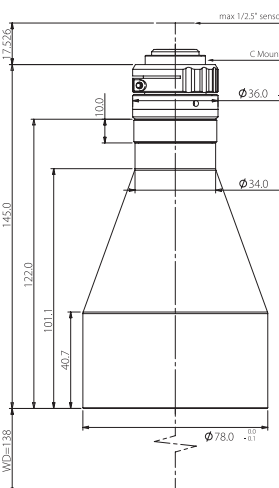

FOV(Φmm)	56
Mag.(x)	0.129
WD(mm)	138±3
Max Sensor Size(Φmm)	7.2(1/2.5")
F/#	4.2
MTF30(lp/mm)	>200
DoF(mm)	±26.4@F11
Distortion(% max)	<0.1
Telecentricity(° max)	<0.1
I/O(mm)	301±3
Length(mm)	145.0
Mount	C-Mount
Weight(kg)	0.7
Field of View(mm×mm)	1/2.5" 9P001/31(5.7x4.28) 44.2x33.2

BTL-0.113X-189-125(LM)

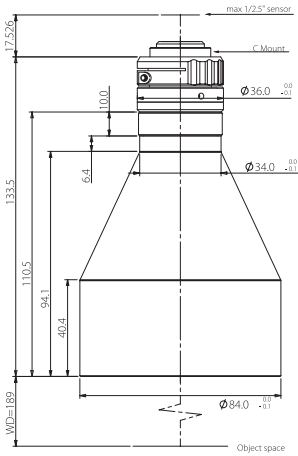

FOV(Φmm)	64
Mag.(x)	0.113
WD(mm)	189±3
Max Sensor Size(Φmm)	7.2(1/2.5")
F/#	4.2
MTF30(lp/mm)	>190
DoF(mm)	±34.4@F11
Distortion(% max)	<0.1
Telecentricity(° max)	<0.1
I/O(mm)	340±3
Length(mm)	133.5
Mount	C-Mount
Weight(kg)	0.8
Field of View(mm×mm)	1/2.5" 9P001/31(5.7x4.28) 50.4x37.9

BTL-0.1X-178-125(LM)

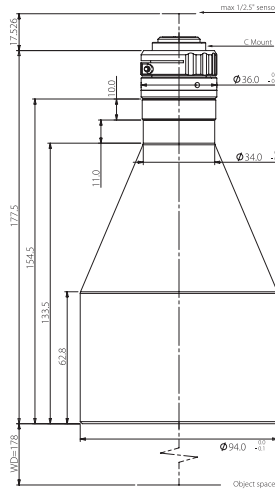

FOV(Φmm)	72
Mag.(x)	0.100
WD(mm)	178±3
Max Sensor Size(Φmm)	7.2(1/2.5")
F/#	4.2
MTF30(lp/mm)	>195
DoF(mm)	±44.0@F11
Distortion(% max)	<0.1
Telecentricity(° max)	<0.1
I/O(mm)	373±3
Length(mm)	177.5
Mount	C-Mount
Weight(kg)	1.0
Field of View(mm×mm)	1/2.5" 9P001/31(5.7x4.28) 57.0x42.8

BTL-0.09X-228-125(LM)

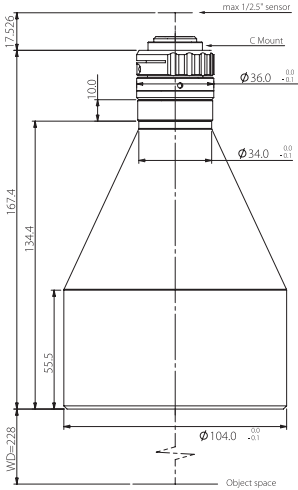

FOV(Φmm)	80
Mag.(x)	0.090
WD(mm)	228±4
Max Sensor Size(Φmm)	7.2(1/2.5")
F/#	4.2
MTF30(lp/mm)	>190
DoF(mm)	±54.3@F11
Distortion(% max)	<0.1
Telecentricity(° max)	<0.1
I/O(mm)	413±4
Length(mm)	167.4
Mount	C-Mount
Weight(kg)	1.5
Field of View(mm×mm)	1/2.5" 9P001/31(5.7x4.28) 63.3x47.6

BTL-0.08X-208-125(LM)

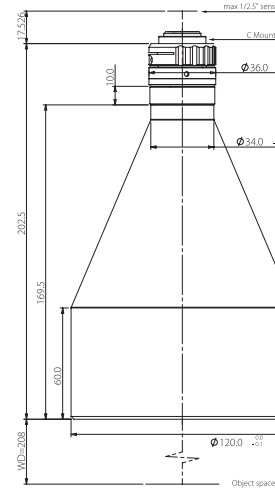

FOV(Φmm)	90
Mag.(x)	0.080
WD(mm)	208±3
Max Sensor Size(Φmm)	7.2(1/2.5")
F/#	4.2
MTF30(lp/mm)	>200
DoF(mm)	±68.7@F11
Distortion(% max)	<0.1
Telecentricity(° max)	<0.1
I/O(mm)	428±3
Length(mm)	202.5
Mount	C-Mount
Weight(kg)	1.7
Field of View(mm×mm)	1/2.5" 9P001/31(5.7x4.28) 71.3x53.5

BTL-0.072X-258-125(LM)

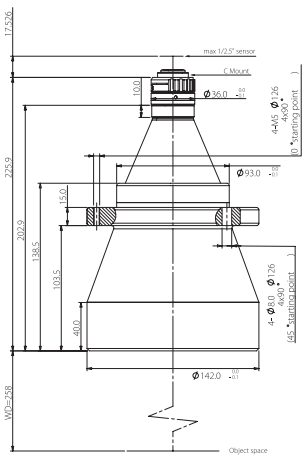

FOV(Φmm)	100
Mag.(x)	0.072
WD(mm)	258±4
Max Sensor Size(Φmm)	7.2(1/2.5")
F/#	4.2
MTF30(lp/mm)	>210
DoF(mm)	±84.8@F11
Distortion(% max)	<0.1
Telecentricity(° max)	<0.1
I/O(mm)	501±4
Length(mm)	225.9
Mount	C-Mount
Weight(kg)	3.0
Field of View(mm×mm)	1/2.5" 9P001/31(5.7x4.28) 79.2x59.4

BTL-0.06X-280-125(LM)

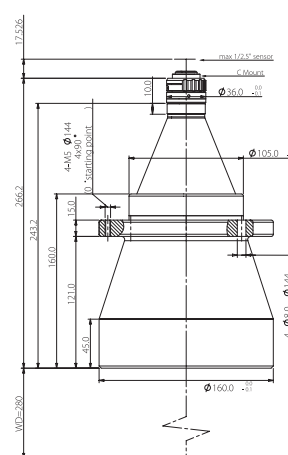

FOV(Φmm)	120
Mag.(x)	0.060
WD(mm)	280±5
Max Sensor Size(Φmm)	7.2(1/2.5")
F/#	4.2
MTF30(lp/mm)	>210
DoF(mm)	±122@F11
Distortion(% max)	<0.1
Telecentricity(° max)	<0.1
I/O(mm)	564±5
Length(mm)	266.2
Mount	C-Mount
Weight(kg)	4.2
Field of View(mm×mm)	1/2.5" 9P001/31(5.7x4.28) 95.0x71.3

BTL-0.048X-300-125(LM)

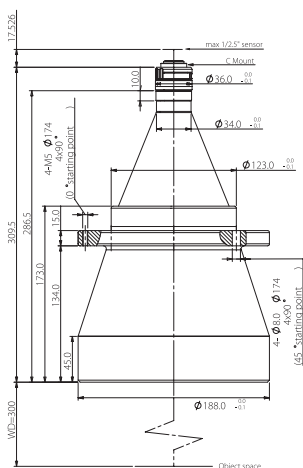

FOV(Φmm)	150
Mag.(x)	0.048
WD(mm)	300±5
Max Sensor Size(Φmm)	7.2(1/2.5")
F/#	4.2
MTF30(lp/mm)	>210
DoF(mm)	±190@F11
Distortion(% max)	<0.1
Telecentricity(° max)	<0.1
I/O(mm)	627±5
Length(mm)	309.5
Mount	C-Mount
Weight(kg)	5.7
Field of View(mm x mm)	118.8x89.2
1/2.5" 9P001/31(5.7x4.28)	118.8x89.2

BTL-0.038X-330-125(LM)

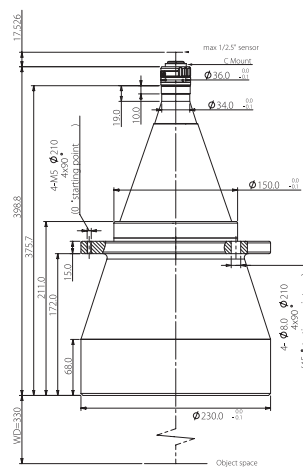

FOV(Φmm)	190
Mag.(x)	0.038
WD(mm)	330±5
Max Sensor Size(Φmm)	7.2(1/2.5")
F/#	4.2
MTF30(lp/mm)	>205
DoF(mm)	±304@F11
Distortion(% max)	<0.1
Telecentricity(° max)	<0.1
I/O(mm)	746±5
Length(mm)	398.8
Mount	C-Mount
Weight(kg)	11.0
Field of View(mm x mm)	150.0x112.6
1/2.5" 9P001/31(5.7x4.28)	150.0x112.6

BTL-0.03X-410-125(LM)

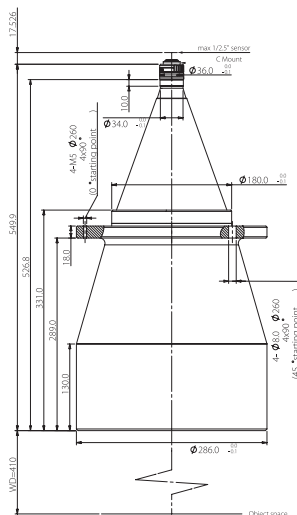

FOV(Φmm)	240
Mag.(x)	0.030
WD(mm)	410±6
Max Sensor Size(Φmm)	7.2(1/2.5")
F/#	4.2
MTF30(lp/mm)	>210
DoF(mm)	±488@F11
Distortion(% max)	<0.1
Telecentricity(° max)	<0.1
I/O(mm)	977±6
Length(mm)	549.9
Mount	C-Mount
Weight(kg)	25.5
Field of View(mm x mm)	190.0x142.7
1/2.5" 9P001/31(5.7x4.28)	190.0x142.7

BTL-0.024X-465-125(LM)

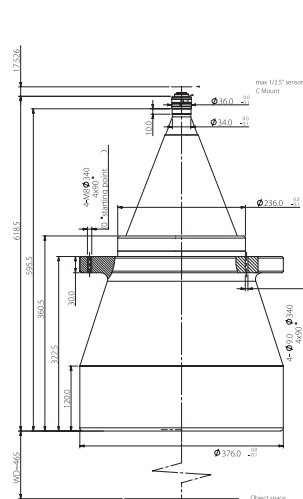

FOV(Φmm)	300
Mag.(x)	0.024
WD(mm)	465±6
Max Sensor Size(Φmm)	7.2(1/2.5")
F/#	4.2
MTF30(lp/mm)	>205
DoF(mm)	±763@F11
Distortion(% max)	<0.1
Telecentricity(° max)	<0.1
I/O(mm)	1101±6
Length(mm)	618.5
Mount	C-Mount
Weight(kg)	46.5
Field of View(mm x mm)	237.5x178.3
1/2.5" 9P001/31(5.7x4.28)	237.5x178.3