



LEO Series

Line Scan Camera



Provided by LEO Series Line Scan Industrial Camera 2K,4K,8K resolution, with very good price compared to provide flexible and simple high-speed solutions.

The camera supports line and frame triggering and many other operations mode. Especially suitable for demanding applications, such as flat board display inspection, PCB inspection, textile quality inspection and paper quality check.

LEO series industrial cameras cover GigE gigabit Ethernet and Camera Link data bus standard, support GenICam™, Cameralink and GigEVision®, optional sewing with third parties such as HALCON and Vision Pro Software without secondary development.

At the same time, LEO series industrial cameras provide the foundation designed for Windows and Linux versions industrial SDK, providing rich advanced control interface complete functions.

Features

- Compatible with GenICam™、GigE Vision® protocol, CameraLink standard
- Seamless access to third-party software.
- Robust industrial housing design.
- Built-in temperature and power real-time monitoring sensor.
- Professional SDK secondary development kit.

Reliability Test

- 24 hours 3G shock experiment.
- 2 weeks -40~60 °C high and low temperature reciprocating test.
- 6kV metal shell electrostatic discharge test.
- 1kV common mode /0.5kV POE power supply surge test.
- Class A standard EMC test.
- 1000mm free fall test.

Dimension

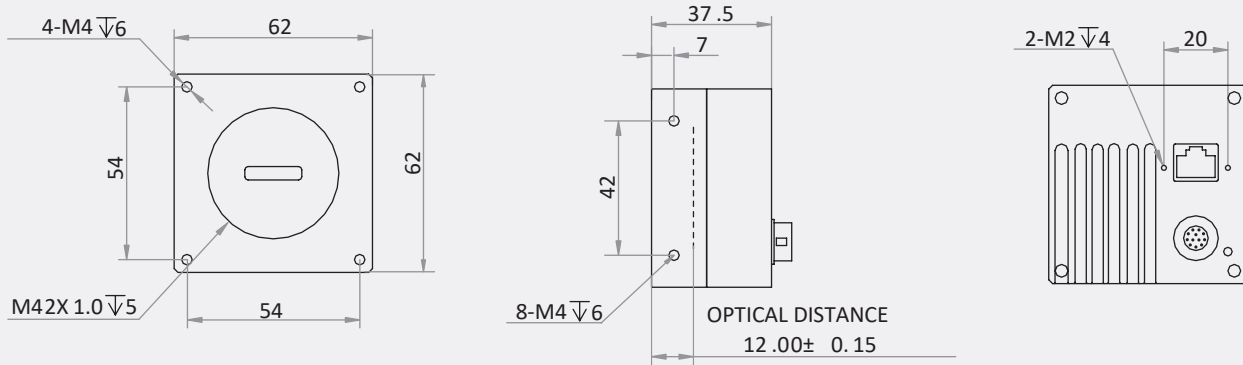

Features

- Adopts GigE interface and max. transmission distance of 100 meters without relay
- Compatible with GigE Vision Protocol, GenICam Standard, and the third-party software based on these protocol and standard
- Support Windows、Linux
- Up to 128 MB local memory for burst transmission and retransmission



Specifications

Model	Resolution	Line Frequency	Data Bit	Pixel	Color	Dynamic Range	SNR
LEO 2048-L32gc	2048*2	32 K	8/10/12 bit	7 × 7	Color	60dB	40dB
LEO 2048-L56gm	2048*1	56 K	8/10/12 bit	7 × 7	Mono	60dB	40dB

Camera Parameters	
Lenses Mount	M42*1, FBL 12mm
Exposure Time	2μs~10ms
Interface	GigE Vision
Conformity	GigE Vision V2.0, GenICam
Synchronization	hardware trigger、software trigger、free run mode
Digital I/O	12-pin Hirose connector provides power and I/O, including differential input × 2 (Line 0, Line 3), differential output × 2 (Line 1, Line 4), and bi-directional non-isolated I/O × 1 (Line 2)
Power Input	DC 12V,PoE
Power Consumption	4 W@12 VDC
Temperature	-30~70°C (Storage) / 0~50°C (Working)
Housing Size	62 mm × 62 mm × 37.5 mm
Weight	170 g

Dimension

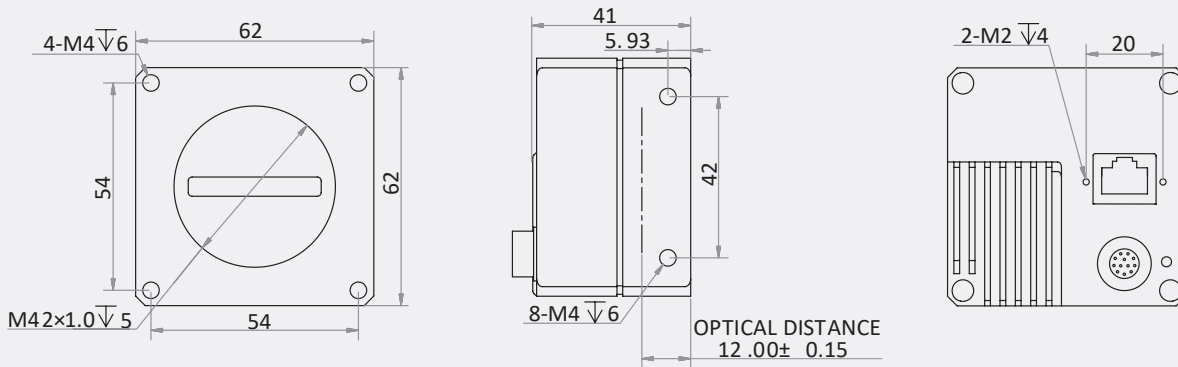

Features

- Adopts GigE interface and max. transmission distance of 100 meters without relay
- Compatible with GigE Vision Protocol, GenICam Standard, and the third-party software based on these protocol and standard
- Support Windows、Linux
- Up to 128 MB local memory for burst transmission and retransmission



Specifications

Model	Resolution	Line Frequency	Data Bit	Pixel	Color	Dynamic Range	SNR
LEO2 2048G-L19gc	2048 × 2	19/40 K	8/10/12 bit	14 × 14	Color	63.4dB	39.4dB
LEO2 2048G-L56gm	2048 × 1	56/100 K	8/10/12 bit	14 × 14	Mono	63.4dB	39.4dB
LEO2 4096G-L19gc	4096 × 2	19/80 K	8/10/12 bit	7 × 7	Color	65.6dB	40dB
LEO2 4096G-L28gm TDI	4096 × 2 (1 Line/2 TDI)	28/80 K	8/10/12 bit	7 × 7	Mono	65.6dB	40dB

Camera Parameters	
Lenses Mount	M42*1, FBL12mm
Exposure Time	5μs~10ms
Interface	GigE Vision
Conformity	GigE Vision V2.0, GenICam
Synchronization	hardware trigger、software trigger、free run mode
Digital I/O	12-pin connector provides power and I/O: configurable input and output × 4 (Line 0/1/3/4), and support single-end/differential
Power Input	DC 12V-24V,PoE
Power Consumption	LEO2 2048G-L19gc: 7.4 W@12 VDC / LEO2 2048G-L56gm: 5 W@12 VDC LEO2 4096G-L19gc: 6.6 W@12 VDC / LEO2 4096G-L28gm: 5.8 W@12 VDC
Temperature	-30~80°C (Storage) / -20~55°C (Working)
Housing Size	62 mm × 62 mm × 41 mm
Weight	280 g

Dimension

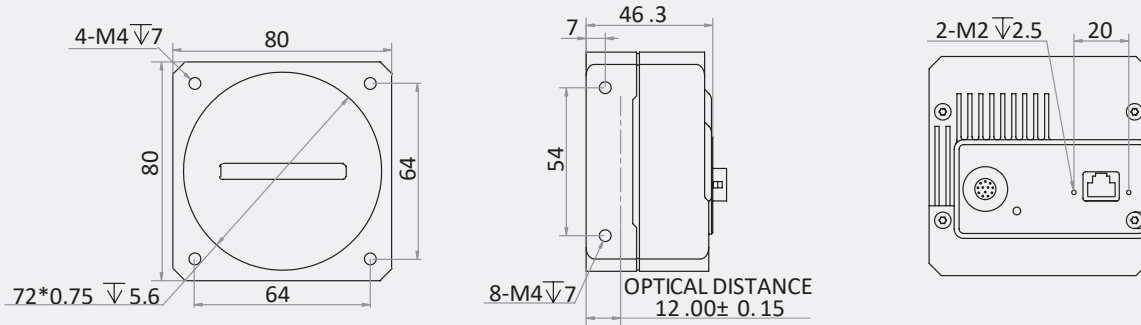

Features

- Adopts GigE interface and max. transmission distance of 100 meters without relay
- Compatible with GigE Vision Protocol, GenICam Standard, and the third-party software based on these protocol and standard
- Support Windows、Linux
- Up to 512 MB local memory for burst transmission and retransmission



Specifications

Model	Resolution	Line Frequency	Data Bit	Pixel	Color	Dynamic Range	SNR
LEO 8192G-L14gm TDI	8192 × 4 (1line/2-TDI/4-TDI)	14/40 K	8/10/12 bit	5 × 5	Mono	54.8dB	40.3dB
LEO 8192G-L14gc TDI	8192 × 6 (1line/2-TDI)	14/40 K	8/10 bit	5 × 5	Color	54.8dB	40.3dB

Camera Parameters	
Lenses Mount	M72*0.75, FBL 12mm
Exposure Time	3μs~10ms
Interface	GigE Vision
Conformity	GigE Vision V2.0, GenICam
Synchronization	hardware trigger、software trigger、 free run mode
Digital I/O	12-pin connector provides power and I/O: configurable input and output × 4 (Line 0/1/3/4), and support single-end/differential
Power Input	DC 12V-24V
Power Consumption	LEO 8192G-L14gm: 12.4 W@12 VDC / LEO 8192G-L14gc: 13 W@12 VDC
Temperature	-30~80°C (Storage) / -20~55°C (Working)
Housing Size	80 mm × 80 mm × 46.3 mm
Weight	465 g

Dimension

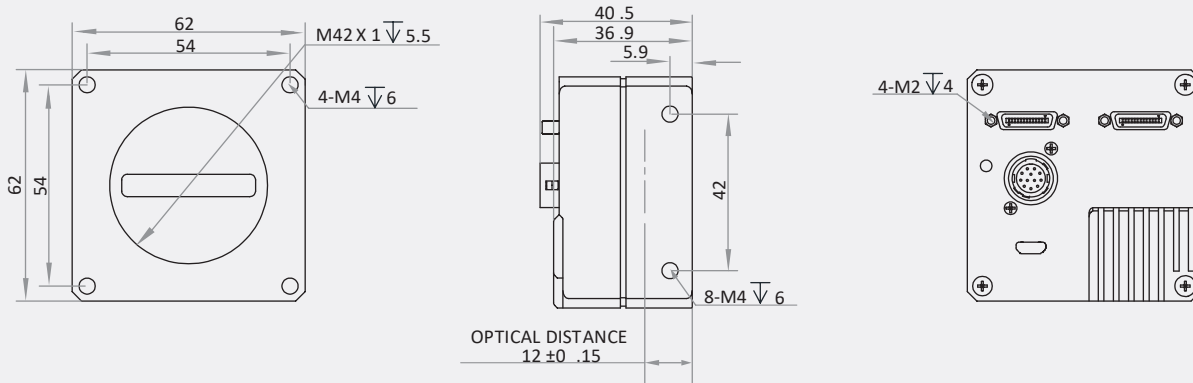

Features

- Adopts CameraLink interface to transmit data
- Supports four configuration modes: Base, Medium, Full and 80-bit
- Compatible with CameraLink Vision Protocol, GenICam Standard, and the third-party software based on these protocol and standard
- Support Windows



Specifications

Model	Resolution	Line Frequency	Data Bit	Pixel	Color	Dynamic Range	SNR
LEO 4KT2-100cm TDI	4096 × 2 (1line/2-TDI)	50/100 K	10/12 bit	7 × 7	Mono	65.6dB	40dB
LEO 4K-100cc	4096 × 2	100 K	8 bit	7 × 7	Color	65.6dB	40dB

Camera Parameters	
Lenses Mount	M42*1, FBL12mm
Exposure Time	5μs~10ms
Interface	Camera LinK
Conformity	Camera Link V2.1, GenICam
Synchronization	hardware trigger、 software trigger、 free run mode
Digital I/O	12-pin connector provides power and I/O: configurable input and output × 4 (Line 0/1/3/4), and support single-end/differential; Camera Link provides IO (CC1/CC2/CC3/CC4)
Power Input	DC 12V-24V
Power Consumption	LEO 4KT2-100cm: 6.1 W@12 VDC / LEO 4K-100cc: 5.5 W@12 VDC
Temperature	-30~80°C (Storage) / -20~55°C (Working)
Housing Size	62 mm × 62 mm × 36.9 mm
Weight	238 g

Dimension

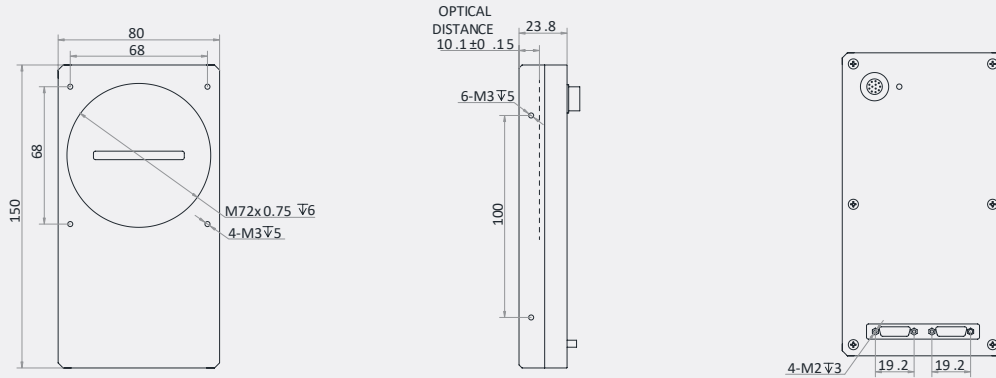

Features

- Adopts CameraLink interface to transmit data
- Supports four configuration modes: Base, Medium, Full and 80-bit
- Compatible with CameraLink Vision Protocol, GenICam Standard, and the third-party software based on these protocol and standard
- Support Windows



Specifications

Model	Resolution	Line Frequency	Data Bit	Pixel	Color	Dynamic Range	SNR
LEO 8KT2-34cc TDI	8192*6 (1-line/2-TDI)	34 K	8 bit	5*5	Color	62dB	42dB
LEO 8KT4-100cm TDI	8192*4 (1-line/2-TDI/4-TDI)	100K	8/10 bit	5*5	Mono	62dB	42dB

Camera Parameters	
Lenses Mount	M72*0.75, FBL 10.1 mm
Exposure Time	3 μ s~10ms
Interface	Camera Link
Conformity	Camera LinkV1.2, GenICam
Synchronization	hardware trigger、software trigger、free run mode
Digital I/O	12-pin connector provides power and I/O: configurable input and output \times 4 (Line 0/1/3/4), and support single-end/differential; Camera Link provides IO (CC1/CC2/CC3/CC4)
Power Input	12 ~ 24 VDC
Power Consumption	LEO 8KT2-34cc: 12.3W@12 VDC LEO 8KT4-100cm: 12.3 W@12 VDC
Temperature	-30~70°C (Storage) / 0~50°C (Working)
Housing Size	150 mm \times 80 mm \times 23.8 mm
Weight	400 g

Dimension

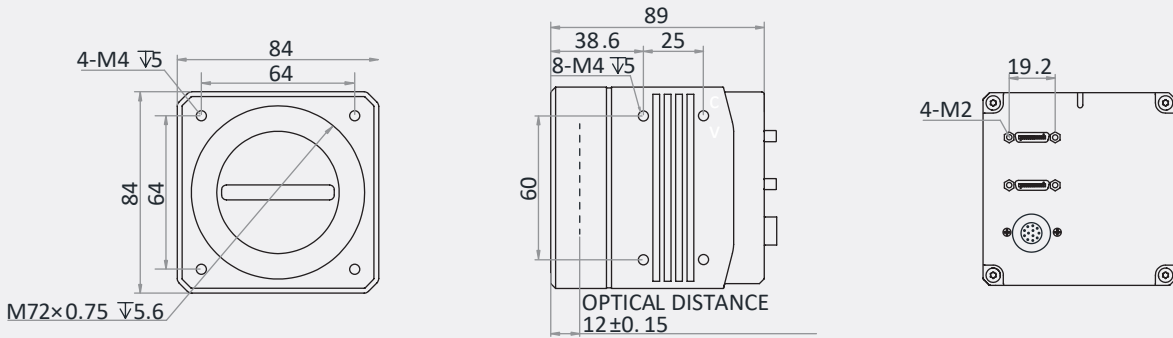

Features

- Adopts CameraLink interface to transmit data, support Sequence Strobe and TDI
- Supports four configuration modes: Base, Medium, Full and 80-bitt
- Compatible with CameraLink Vision Protocol, GenICam Standard, and the third-party software based on these protocol and standard
- Support Windows

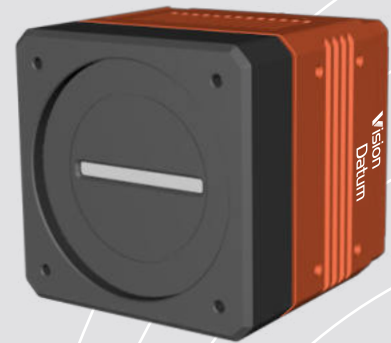

Specifications

Model	Resolution	Line Frequency	Data Bit	Pixel	Color	Dynamic Range	SNR
LEO 8KT4S-100CM TDI	8192 × 16 (1-line/2-TDI/4-TDI)	5/100 K	8/10 bit	5*5	Mono	57.8dB	41.3dB
LEO 8KT4-34cc TDI	8192 × 12 (1-line/2-TDI/4-TDI)	34 K	8/10 bit	5*5	Color	62dB	42dB

Camera Parameters	
Lenses Mount	M72*0.75, FBL 12mm
Exposure Time	3 μ s ~ 10 ms
Interface	Camera Link
Conformity	Camera LinkV1.2, GenICam
Synchronization	hardware trigger、 software trigger、 free run mode
Digital I/O	12-pin connector provides power and I/O: configurable input and output × 4 (Line 0/1/3/4), and support single-end/differential; Camera Link provides IO (CC1/CC2/CC3/CC4)
Power Input	24 VDC
Power Consumption	LEO 8KT4S-100CM: 22.9 W@24 VDC LEO 8KT4-34cc: 20.5 W@12 VDC
Temperature	-30~70°C (Storage) / 0~50°C (Working)
Housing Size	84 mm × 84 mm × 89 mm
Weight	900 g

Dimension

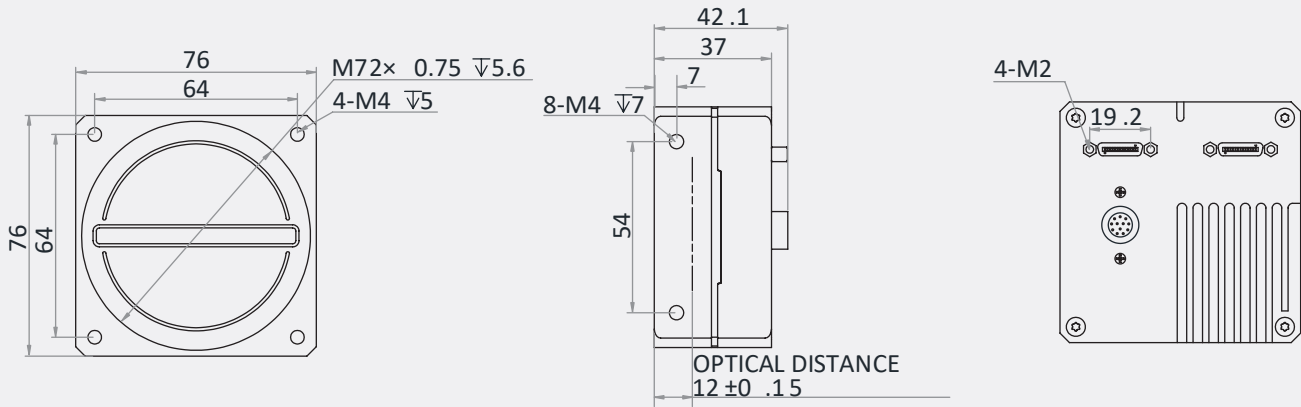

Features

- Adopts CameraLink interface to transmit data
- Supports three configuration modes: Base、Medium and Full
- Compatible with CameraLink Vision Protocol, GenICam Standard, and the third-party software based on these protocol and standard
- Support Windows



Specifications

Model	Resolution	Line Frequency	Data Bit	Pixel	Color	Dynamic Range	SNR
LEO 8K-74CM	8192 × 1	74 K	8/10/12 bit	7 × 7	Mono	64.7dB	44.3dB
LEO 16K-40CM	16384 × 1	40 K	8/10/12 bit	3.5 × 3.5	Mono	64.7dB	44.3dB

Camera Parameters	
Lenses Mount	M72*0.75, FBL12mm
Exposure Time	2 μs ~ 10ms
Interface	Camera Link
Conformity	Camera LinkV1.2, GenICam
Synchronization	hardware trigger、software trigger、free run mode
Digital I/O	12-pin connector provides power and I/O: configurable input and output × 4 (Line 0/1/3/4), and support single-end/differential; Camera Link provides IO (CC1/CC2/CC3/CC4)
Power Input	12 ~ 24 VDC
Power Consumption	LEO 8K-74CM: 5.8 W@12 VDC / LEO 16K-40CM: 7.2 W@12 VDC
Temperature	-30~70°C (Storage) / 0~50°C (Working)
Housing Size	76 mm × 76 mm × 42.1 mm
Weight	320 g

Vision And More Available

让工业更智能，让视觉更简单！



SWIR/LWIR Camera
Industrial Camera



Macro Lens
Industrial Lens



Microscope



System Solution
No-programming Software

Hangzhou Vision Datum Technology Co., Ltd.

Tel: 86-571-86888309
www.visiondatum.com



VER 2022.07